

**create  
space**  
and never  
forget



**EXPANDABLE**  
movable spaces

User manual

POD

25ft

# Table of contents

1. Description .....	2
1.1 Pod .....	3
1.1.1 Hydraulic Control .....	6
2. Remote Control .....	8
2.1 Remote Control Expandable Pod .....	9
2.1.1 Pairing the Remote Control .....	12
3. Preparation for Use .....	15
3.1 Preparing for Use .....	16
4. Commissioning .....	21
4.1 Power Disconnect .....	22
5. Preparation for Transport .....	23
5.1 Preparing for Transport .....	24
6. Emergency Operation .....	29
6.1 Accessibility Expandable Pod in case of malfunction .....	30
7. Periodic Maintenance .....	31
7.1 Maintenance Schedule .....	32
7.1.1 Oil Level .....	34
7.1.1.1 Refilling Oil .....	36
8. Safety & Environment .....	37
8.1 Environment .....	38
8.2 Safety During Use .....	38
9. General Information .....	39
9.1 Cleaning .....	40
9.2 Vehicle Registration and Delivery .....	41
9.3 Site Conditions .....	42
9.4 Access to the Technical Area .....	44
9.5 Checking and Recharging Battery .....	46
9.6 Stickers .....	47
9.6.1 Type Plate .....	49
9.7 Pod Specifications .....	50
9.8 Oil Specifications .....	51

---

9.8.1 Oil Properties .....	51
9.9 Lubricant Properties and Specifications .....	52
9.10 Electrical Component Specifications .....	53
9.11 Pictograms .....	55

# Preface

 This manual is intended for drivers and/or other users of the Expandable Pod and contains the necessary information about its use. This user manual must always be kept with the vehicle. For service technicians, a separate maintenance and repair manual is available via the website: [www.expandable-trailers.com/na](http://www.expandable-trailers.com/na).

## Proper use:

A Expandable Pod is designed for independent use. Modifications of any kind can affect the safety of the system. Warranty on products from Expandable LLC void if these products are modified. If the Expandable Pod is not used according to the instructions provided by Expandable LLC, all warranty claims against Expandable LLC or suppliers of the Expandable Pod will be declared invalid.

Before the system is put into operation, it must be established that the trailer complies with national road traffic legislation. The system may only be operated in accordance with the manuals of the tractor and the trailer.

The images in this manual are for example purposes only and are not intended for any other purpose. The shown images may differ slightly from the delivered system.



## Contact information

Expandable LLC  
 7021 Augusta road  
 Piedmont  
 (864)-400-5095  
[www.expandable-trailers.com/na](http://www.expandable-trailers.com/na)  
[info@expandable-usa.com](mailto:info@expandable-usa.com)

### Validity and copyright:

No part of this document may be reproduced and/or published by printing, photocopying, microfilm, or any other means without written permission from Expandable LLC. The images and specifications have been compiled with great care, but we cannot accept any liability for any deviations. Expandable LLC reserves the right to make technical changes to parts without prior notice. For information on this subject, please contact Expandable LLC.

© Copyright Expandable LLC, Piedmont, United States of America  
 Date of issue: 3/31/2026 Original version: 1.0

## 1. Description

*This chapter describes the Expandable Pod. Here you will find information about the naming of components and their functions.*

## 1.1 Pod

### Main Components

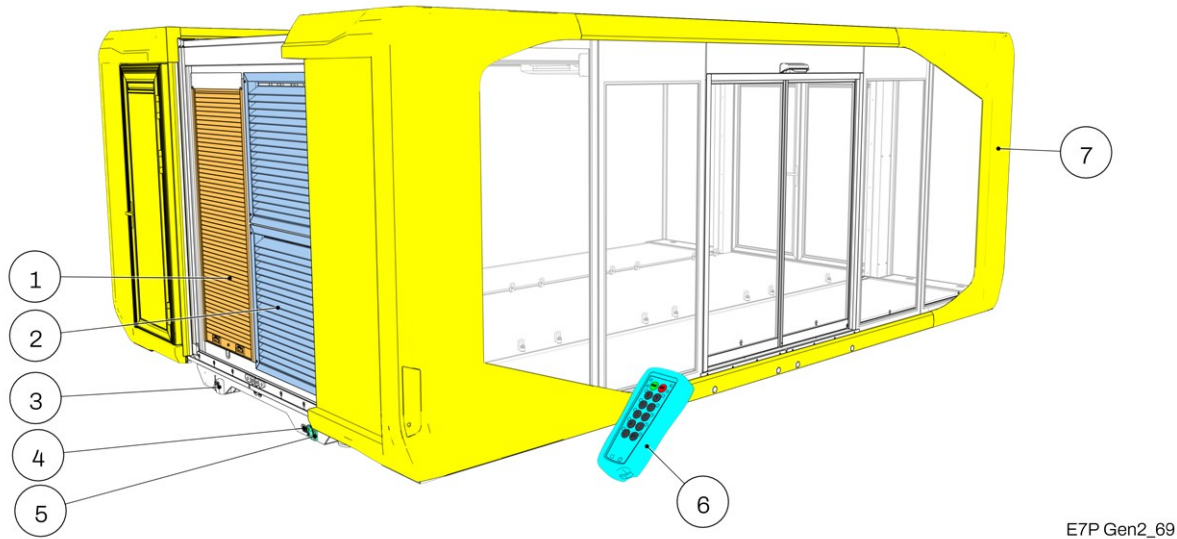

E7P Gen2\_69

Fig. 1-1

1 Roller Shutter Door - Technical Compartment  
 2 Ventilation Grille  
 3 Key safe  
 4 Type Y connector

5 Battery disconnect switch  
 6 Remote control  
 7 Slide outs

### Usage

During normal use of the Expandable Pod, power is supplied via a shore power connection. The extension cord provided for this purpose is located in the technical area and is accessible through a roll-up door. The extension cord can be routed outside through the opening beneath the roll-up door and then connected to the shore power supply. The hydraulic system operates on its own 24V battery system. Depending on the selected configuration, the trailer may be equipped with optional lashing eyelets to secure cargo on board. The number of built-in wall outlets and floor outlets also depends on the selected configuration.

## Key safe

The Expandable Pod is equipped with a key safe located on the chassis at the front of the Expandable Pod (see "Image 1-2"). The key safe is secured with a configurable code. The keys for the access doors are stored in the key safe, ensuring they are always kept near the trailer.

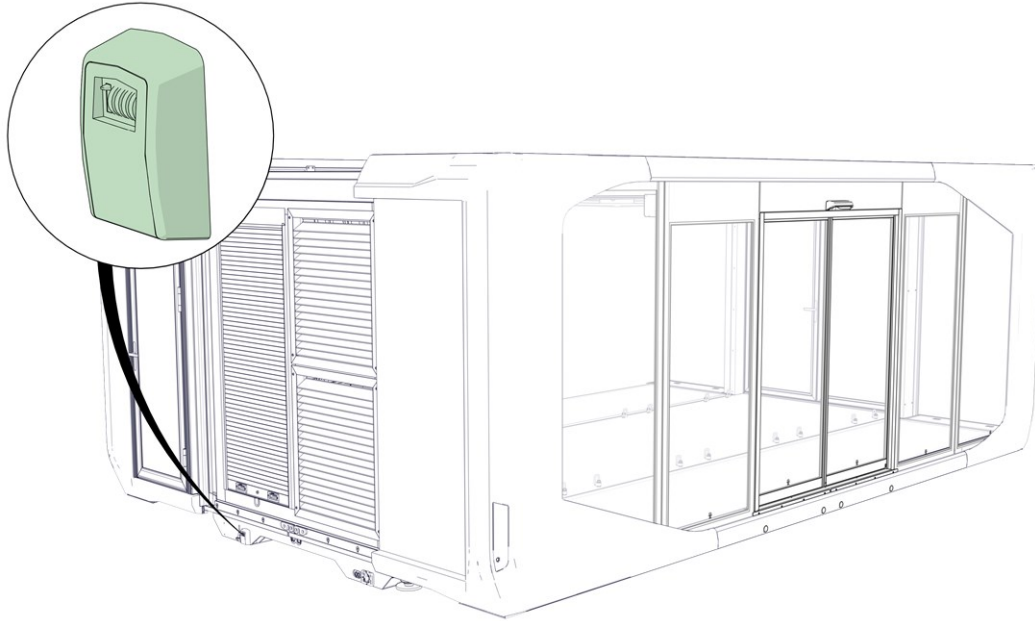

E7P Gen2\_46

Image 1-2 Key safe

## Technical Area

The technical area is located inside the Expandable Pod and contains the hydraulic control system, the air conditioning condenser, and the electrical control system.

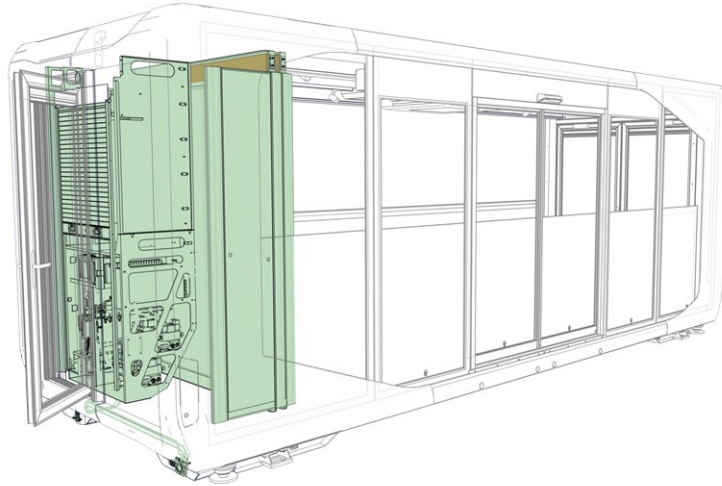

E7P Gen2\_57

*Image 1-3 Technical Area*

The technical area is located inside the Expandable Pod and contains the hydraulic control system, the air conditioning condenser, and the electrical control system. Access to the roll-up door is provided through the hatch in the segment, allowing entry to the technical area.

## Remote control

The Expandable Pod can be operated through a remote control (See ["Remote Control Expandable Pod on page 9"](#)).



P-10107\_01

## 1.1.1 Hydraulic Control

The hydraulic system of the Expandable Pod is operated using the components listed below.

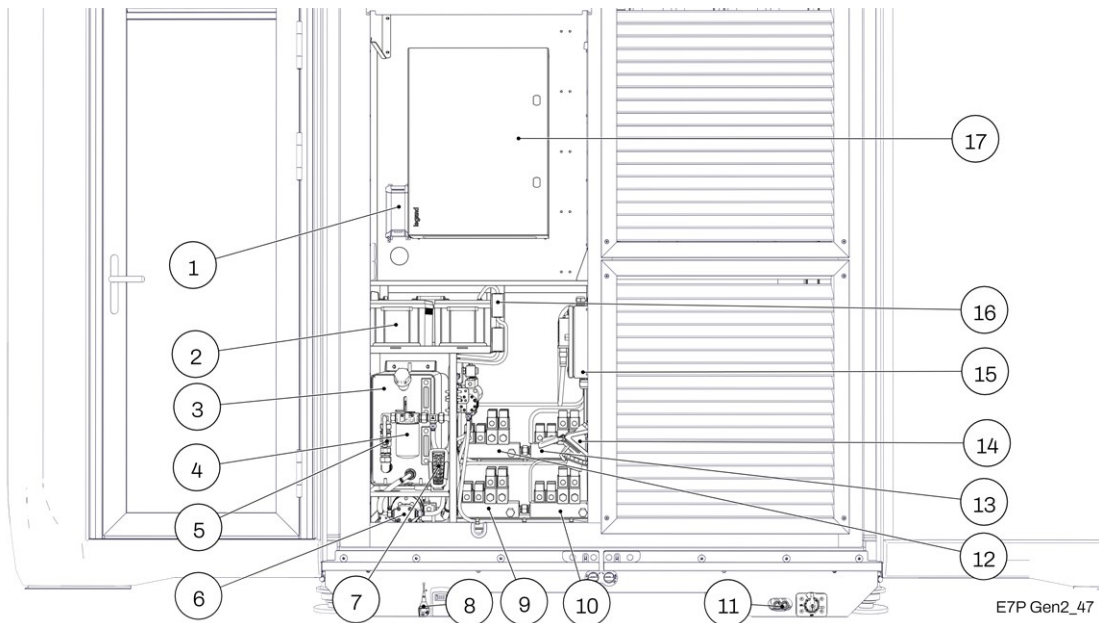

1 Tickle Loader	10 Hydraulic valves
2 Batteries	11 Type Y connector
3 Hydraulic fluid tank	12 Hydraulic valves
4 Hydraulic Filter	13 Hydraulic valves
5 Valve	14 Shore power connector
6 Hydraulic pump	15 Sistematica control box
7 Remote control	16 Charging fuses
8 Antenna	17 Control box
9 Hydraulic valves	

### 1. Trickle Charger

The trickle charger maintains the charge of both 12V batteries when the Expandable Pod is connected to shore power and disconnected from the tractor.

### 2. Batteries

The hydraulic system operates at 24V. To achieve this, two 12V batteries are connected in series.

### 3. Hydraulic fluid tank

This tank contains the hydraulic fluid required to extend and retract the piston rods.

### 4. Hydraulic Filter

The hydraulic filter removes contaminants from the hydraulic fluid and should be replaced at regular intervals. (See "Maintenance Schedule on page 1").

### 5. Valve Manifold

This valve can be used to shut off the oil flow to the filter, allowing the filter to be replaced.

### 6. Hydraulic Pump

The hydraulic pump converts mechanical energy into hydraulic power. By pressurizing and directing hydraulic oil through an energized valve within a closed system, it causes the piston rod to move.

### 7. Remote Control

The hydraulic system can be operated remotely using the remote control.

### 8. Antenna

The antenna is responsible for transmitting and receiving signals to and from the remote control.

### 9. Hydraulic Valves

These valve manifolds control the inward and outward movement of the slide-outs once one of the corresponding buttons on the remote control has been pressed.

- 
10. **Hydraulic valves**
  11. **Type Y connector**

The type y connector is a high-quality connector designed for the safe and reliable transfer of high current, primarily for battery charging applications.
  12. **Hydraulic Valves**
  13. **Hydraulic Valves**
  14. **Shore Power Connector**

The shore power connection is used to safely connect the Expandable Pod to the local electrical power supply.
  15. **Sistematica Control box**
  16. **Charging fuses**

These fuses protect the charging system, the hydraulic pump, and the control box from electrical overload.
  17. **Control box**

Control box contains all electrical connections for operating the hydraulic system.

## 2. Remote Control

*This chapter describes the remote control and button functions.*

## 2.1 Remote Control Expandable Pod



P-10107\_01



*The remote control is stored in the pod's technical area.*

The Expandable Pod can be prepared for operation and transport using the remote control. The remote control has two operating modes. The first mode becomes active when the “START” and “1” buttons are pressed simultaneously for a short time. In this mode, buttons 1 through 10 can be used.

The second mode becomes active when the “START” and “2” buttons are pressed simultaneously for a short time. In this mode, buttons 11 through 20 can be used.



*The buttons 11 through 20 are indicated by the small indicator lights above buttons 1 through 10.*

The remote control buttons activate the corresponding movement for as long as they are pressed. As soon as a button is released, the movement stops. The “STOP” button can also be used to interrupt an active movement; however, this is generally not necessary, as no background processes are running.



*The stop button is **NOT** an emergency stop.*

*Note;*

Stickers are placed on the Expandable Pod. These are shown in the table below. The numbers on the stickers correspond to the buttons on the remote control and indicate the direction of movement of the piston rods.

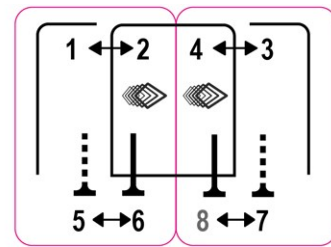
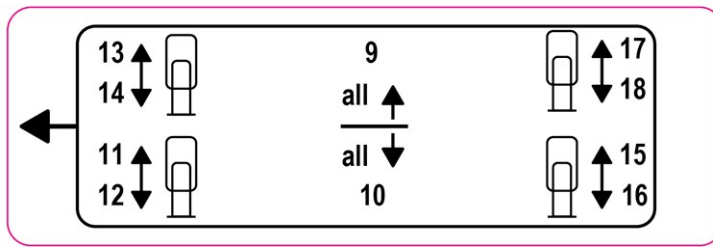

Button	Function	Description	Sticker
1	Extend Left slide-out	Extend Piston Rod	1 ↔ 2
2	Retract left slide-out	Retract Piston Rod	
3	Extend right slide-out	Extendt Piston Rod	4 ↔ 3
4	Retract right slide-out	Retract Piston Rod	
5	Extend left lift cylinder	Extend Piston Rod	6 ↔ 5
6	Retract left lift cylinder	Retract Piston Rod	
7	Extend right lift cylinder	Extend Piston Rod	7 ↔ 8
8	Retract right lift cylinder	Retract Piston Rod	
9	Pod down	Retract all Piston Rods	9 all ↑ all ↓ 10
10	Pod up	Extend all Piston Rods	
11	Pod front left down	Retract Piston Rod	11 9 ↑ all ↑ ↓ all ↓ 12 10
12	Pod front left up	Extend Piston Rod	
13	Pod front right down	Retract Piston Rod	13 9 ↑ all ↑ ↓ all ↓ 14 10
14	Pod front right up	Extend Piston Rod	
15	Pod rear left down	Retract Piston Rod	15 9 ↑ all ↑ ↓ all ↓ 16 10
16	Pod rear left up	Extend Piston Rod	
17	Pod rear right down	Retract Piston Rod	17 9 ↑ all ↑ ↓ all ↓ 18 10
18	Pod rear right	Extend Piston Rod	

Button	Function	Description	Sticker
	up		
	Level Pod		

Table 2-1 Button functions

## 2.1.1 Pairing the Remote Control

The remote control must be paired with the system receiver if it loses connection for any reason or if the remote control is replaced.

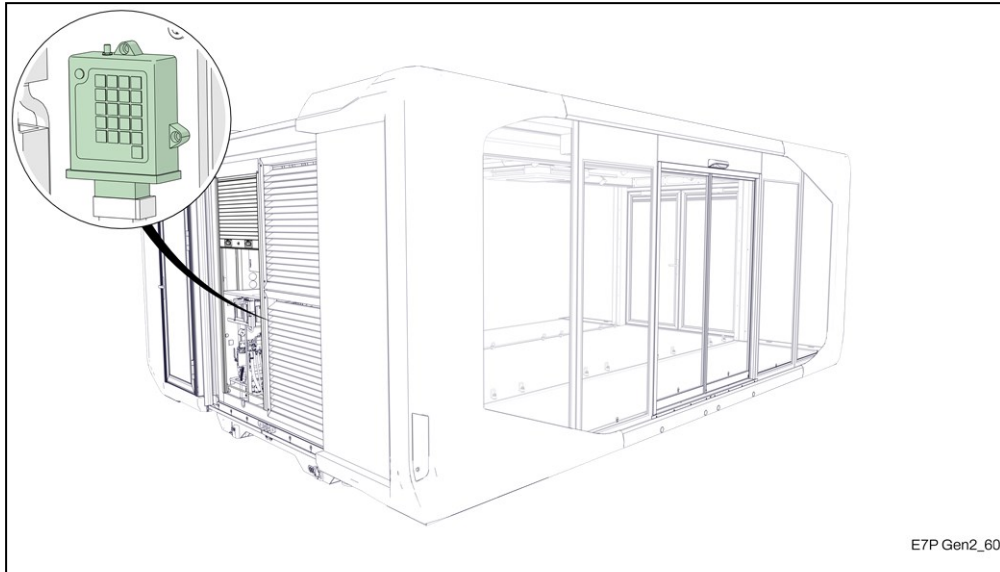

The location of the remote control system receiver is shown above.

### Procedure

1. Turn the battery disconnect switch to the "ON" position.

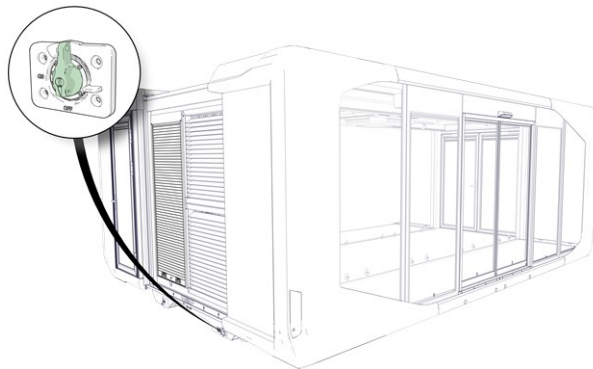

2. Disconnect the plug from the receiver.

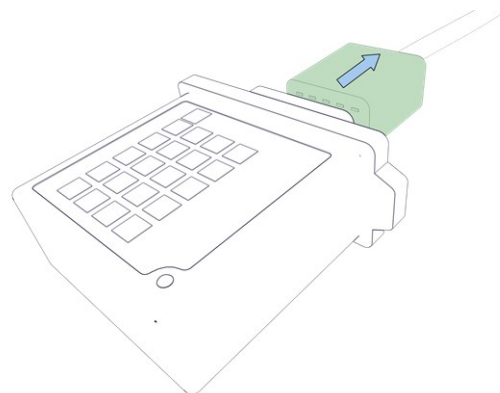

- Stand within a 6.5-foot radius of the receiver with the remote control.

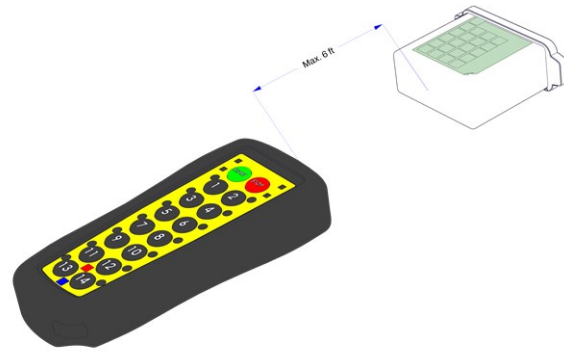

P-10165\_01

- Press the "START" button on the remote control.

 *Press and hold the "START" button.*



P-10165\_03

- While holding down the button "START", connect the plug to the receiver. The LED on the remote control will begin flashing orange.

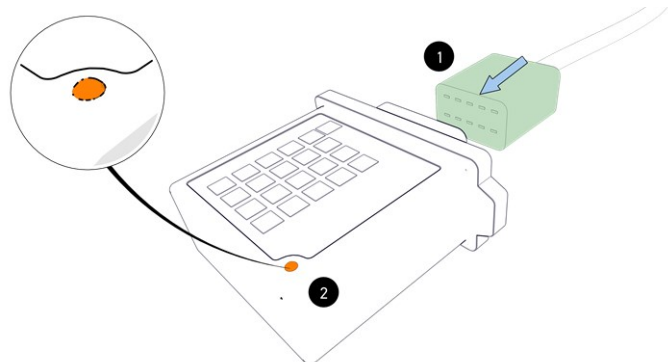

P-10165\_04

- Release the "START" button.
- Within 15 seconds, press three numeric buttons simultaneously. Choose any three numbers from 1 to 14.

 *In this example, buttons 6, 7, and 8 are pressed simultaneously.*



P-10165\_05

8. Release the three numeric buttons as soon as the LED on the receiver begins flashing green. The remote control is now paired with the receiver.

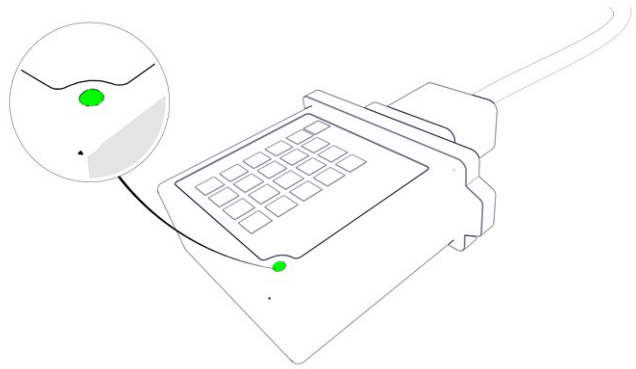

P-10165\_06

Part Number	Description
P-10107	Sistematica Expandable Pod. Remote control 10 buttons 18 functions.
P-10164	Sistematica Set Expandable Pod Remote control 10 buttons 18 functions.
P-10167	Sistematica Receiver CNTR20

Table 2-2 Genuine parts

### 3. Preparation for Use

*In this chapter, you will find information about disconnecting and preparing the Expandable Pod for use.*

### 3.1 Preparing for Use

Follow the procedure below.

1. Turn the battery disconnect switch to the "ON" position.

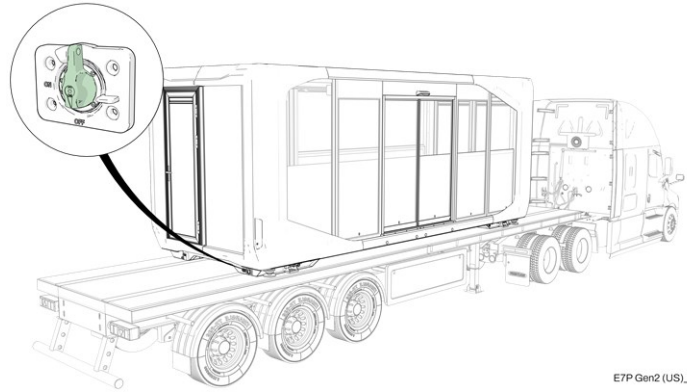

E7P Gen2 (US)\_04

2. Unlock all twist locks or remove any straps or chains securing the Expandable Pod to the trailer.

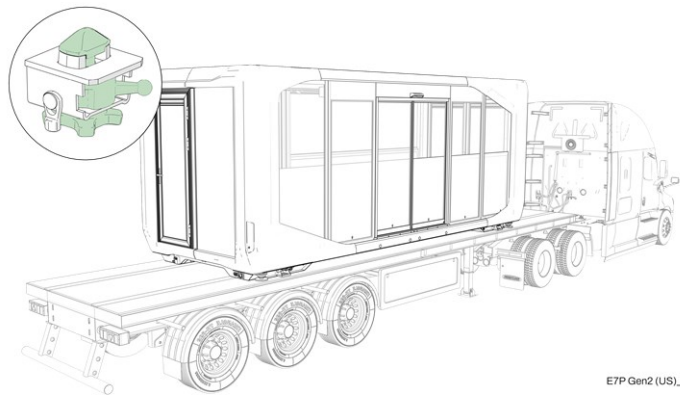

E7P Gen2 (US)\_05

3. Press the indicated remote control button to extend the right-hand slide-out halfway.

		<p><b>Stop immediately if any deformation occurs during extension. Correct the cause of the deformation before continuing to extend the slide-out.</b></p>
--	--	--

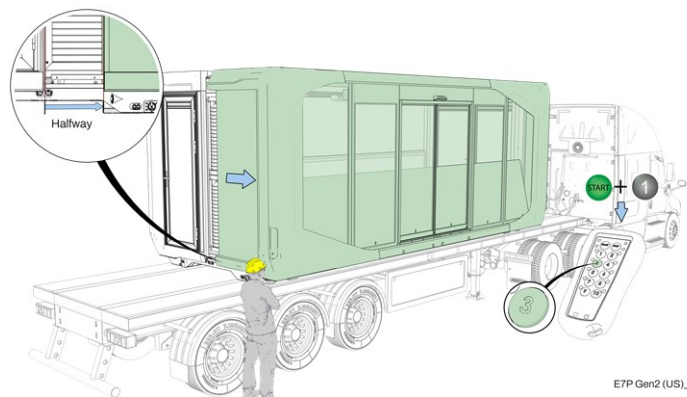

E7P Gen2 (US)\_09

4. Press the indicated remote control button to extend the left-hand slide-out halfway.

		<p><b>Stop immediately if any deformation occurs during extension. Correct the cause of the deformation before continuing to extend the slide-out.</b></p>
--	--	--

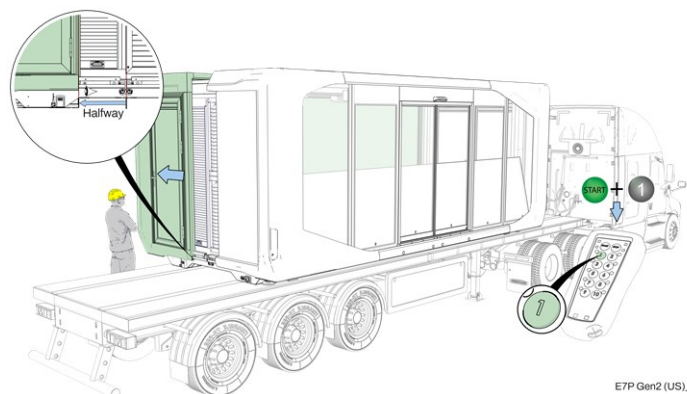

E7P Gen2 (US)\_10

- 5. Press the indicated remote control button to fully extend both right-side lift cylinders.

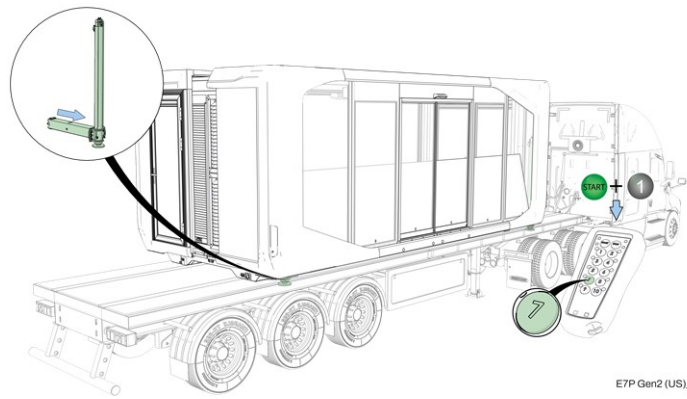

- 6. Press the indicated remote control button to fully extend both left-side lift cylinders.

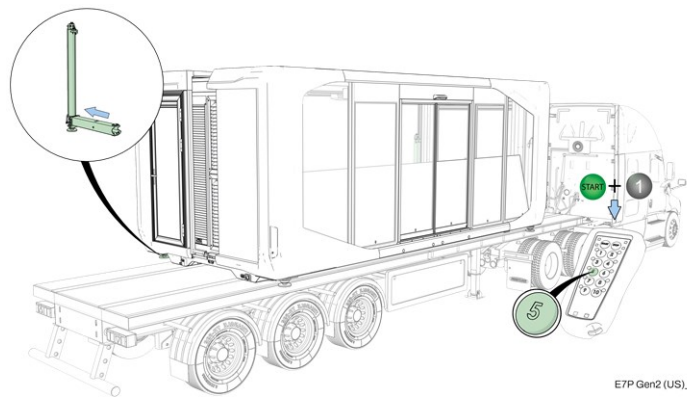

- 7. Press the indicated remote control button to fully extend all lift cylinders.

 **Ensure all piston rod feet are in contact with the ground.**

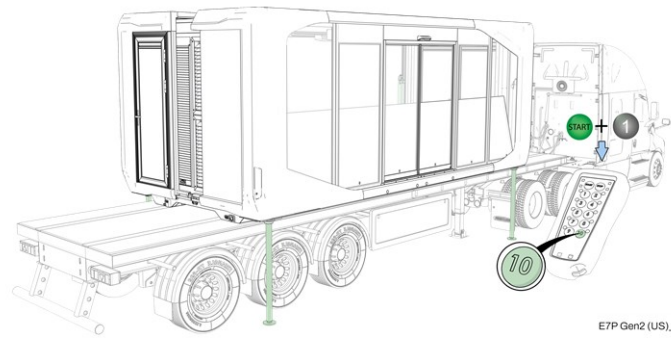

- 8. Press the indicated remote control button to raise the Expandable Pod to its highest vertical position.

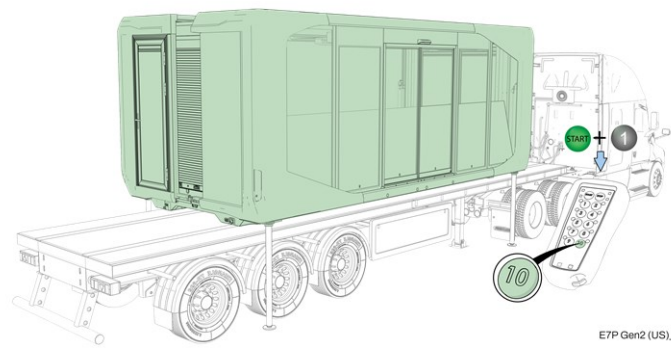

- Carefully drive the tractor and trailer out from under the Expandable Pod.

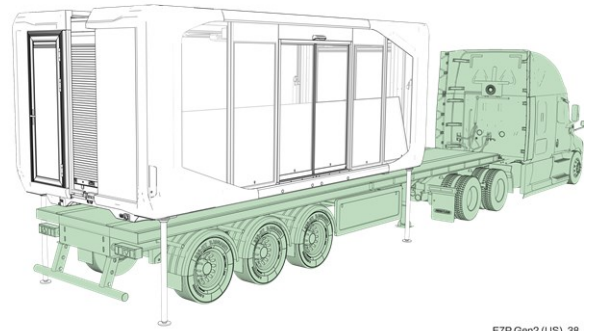

E7P Gen2 (US)\_38

- Press the indicated remote control button to lower the Expandable Pod to the ground.

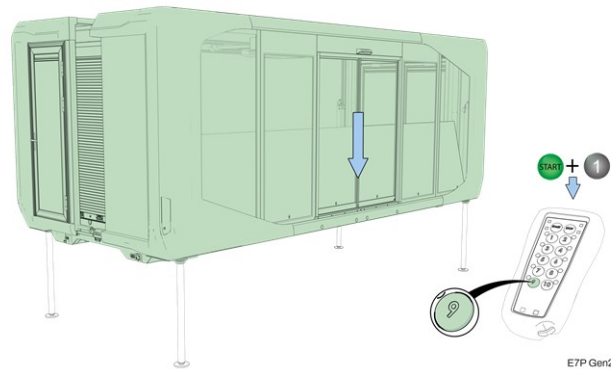

E7P Gen2\_15

- Press the indicated remote control button to fully retract the piston rods of the lift cylinders vertically.

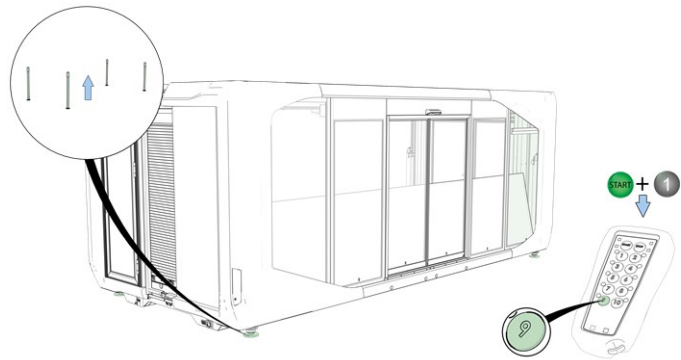

E7P Gen2\_16

- Press the indicated remote control button to fully retract the right-side lift cylinders horizontally.

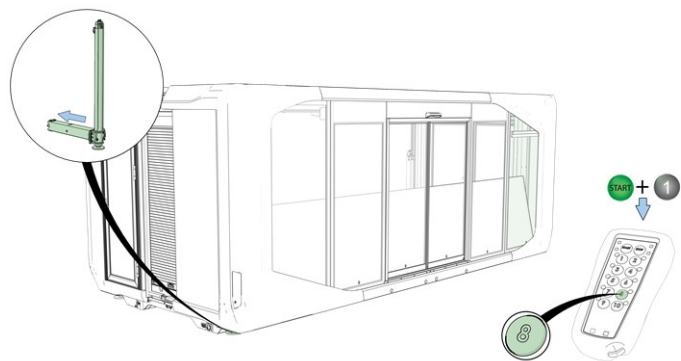

E7P Gen2\_17

- Press the indicated remote control button to fully retract the left-side lift cylinders.

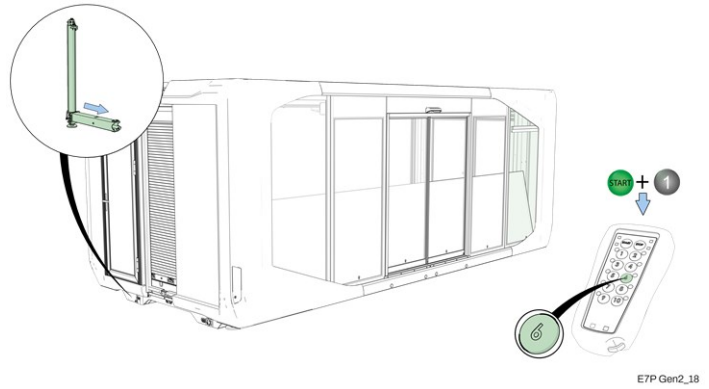

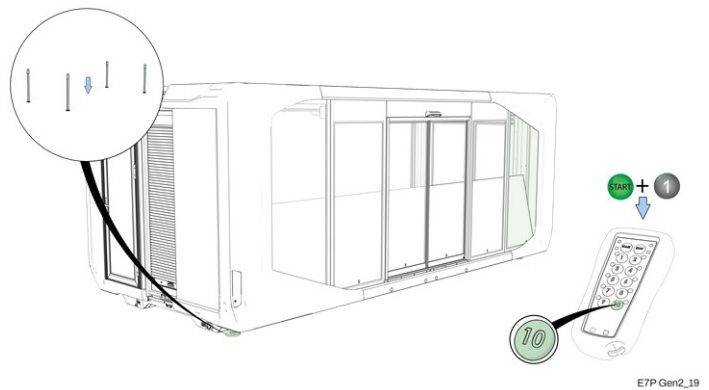

- Press the indicated remote control button to extend the piston rods of the lift cylinders until they contact the ground.

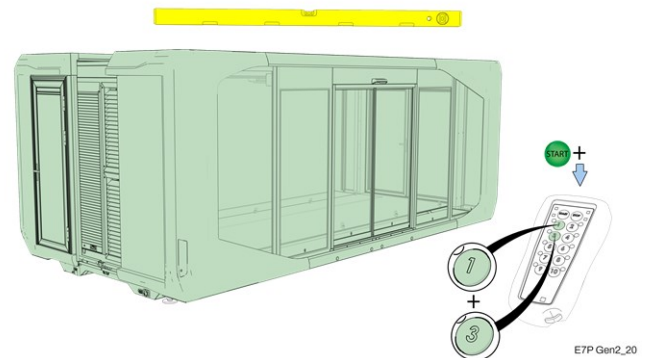

- Press the indicated remote control buttons ("AUTO LEVEL") simultaneously to allow the Expandable Pod to level itself in both directions.





- Press the indicated remote control button to fully extend the right slide-out.

  Stop immediately if any deformation occurs during extension. Correct the cause of the deformation before continuing to extend the slide-out.

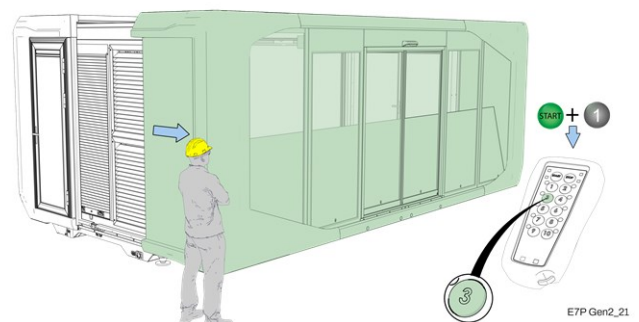
 Please refer to the important note below\*.



17. Press the indicated remote control button to fully extend the left slide-out.

		<p><i>Stop immediately if any deformation occurs during extension. Correct the cause of the deformation before continuing to extend the slide-out.</i></p>
---	---	--

	<p><i>Please refer to the important note below*.</i></p>
---	--

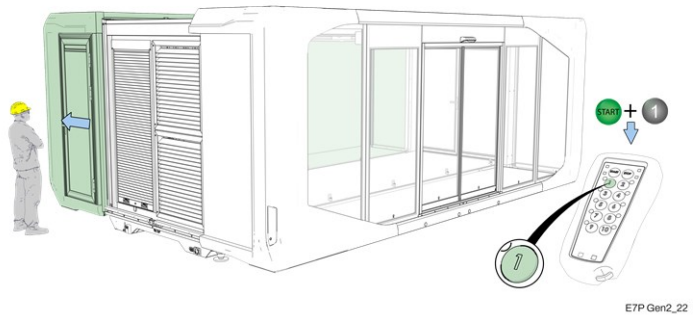

18. Tilt both front floor panels downward.

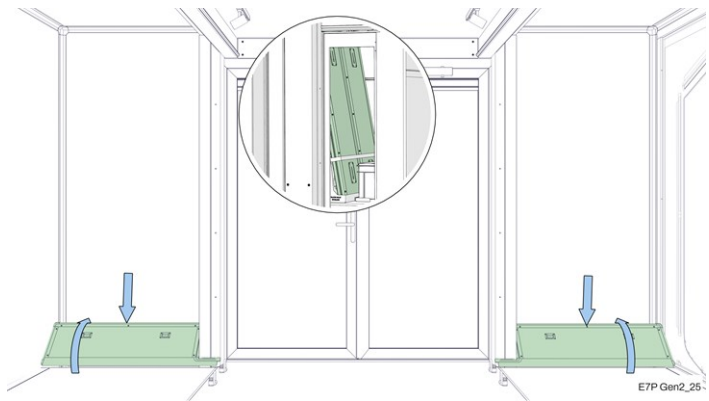

19. Tilt both rear floor panels downward.

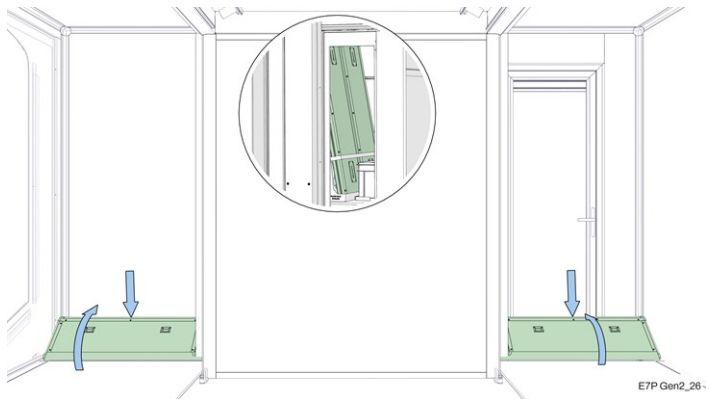

**\*Step 16 and 17:**

*A safety feature is built in: if the front and rear of the container are twisted more than X degrees relative to each other, the slide-outs cannot be extended any further. The automatic leveling function must first be activated. This prevents damage to the slide-outs caused by excessive torsional stress during movement. Continue the procedure from Step 18 onwards.*

## 4. Commissioning

The following paragraphs contain information about the commissioning of the Expandable Pod.

## 4.1 Power Disconnect

Expandable LLC recommends that users of the Expandable Pod temporarily disconnect the power if it is left on site for an extended period. This applies exclusively to the Expandable Pod. All hydraulic equipment can be turned off with the main switch. All other equipment is connected to shore power. If there are external devices connected to the Expandable Pod, such as refrigerators or electronic equipment, it is up to the user to determine whether the power to these devices can be turned off.

Follow the procedure below.

1. ↓ Turn the battery disconnect switch to the "OFF" position to switch off the power.

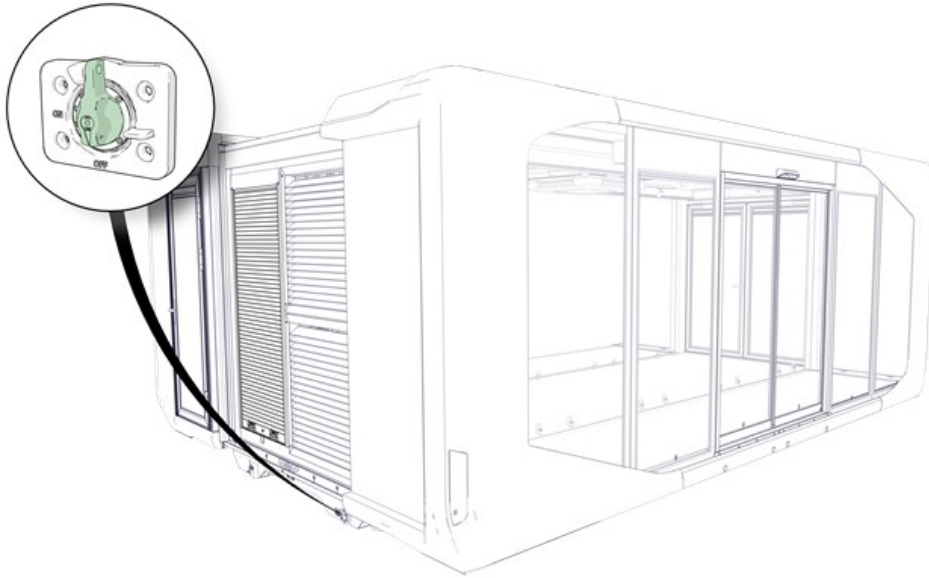

E7P Gen2\_48

Image 4-1



*If necessary, lock the battery disconnect switch with a padlock to prevent unauthorised use.*

## 5. Preparation for Transport

*In this chapter, you will find information on making the Expandable Pod ready for transport and coupling it.*

## 5.1 Preparing for Transport

 Move the load that remains in the Expandable Pod to the centre floor. No load should be placed on the tilting floors.

Follow the procedure below.

1. Switch off all electrical equipment such as air conditioning, lighting and RGB lighting.

 It takes about 5 minutes to empty the air conditioner's water tank.



2. Remove the front floor inserts and store them in their designated location in the technical room.

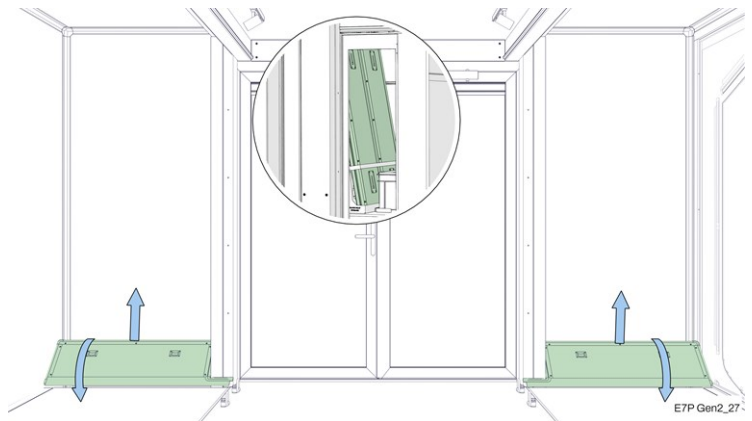

3. Remove the rear floor inserts and store them in their designated location in the technical room.

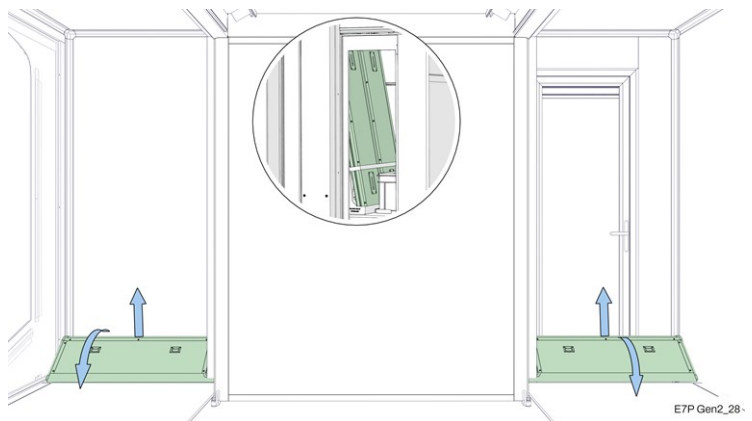

4. Disconnect the shore power and store the cable in the technical room through the roll-up door. Leave the battery disconnect switch in the "ON" position.

 **Close the roll-up door of the technical area**

 **Close all entry doors and store the keys in the key safe (See "Pod on page 3")**

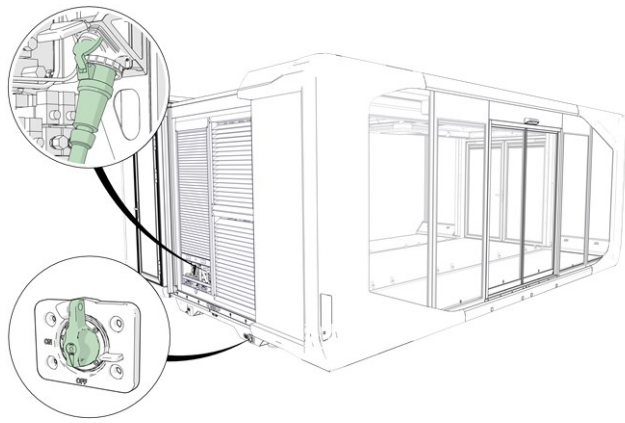

E7P Gen2\_30

5. Press the indicated remote control button to retract the piston rods of the lift cylinders vertically.

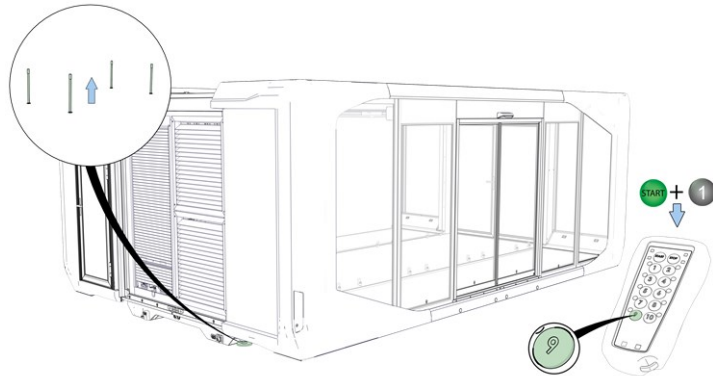

E7P Gen2\_31

6. Press the indicated remote control button to extend the right lift cylinders.

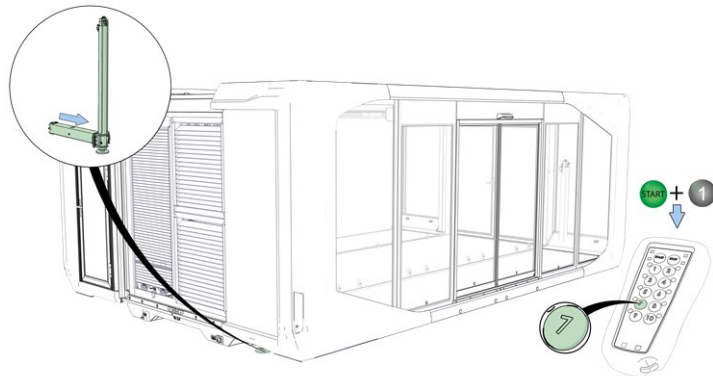



E7P Gen2\_32

7. Press the indicated remote control button to extend the left lift cylinders.



E7P Gen2\_33



- Press the indicated button and retract the left slide out halfway.

		<p><i>While the left slide out is moving pay close attention to the sound and movement. Stop immediately if any deformation occurs during extension. Correct the cause of the deformation before continuing to extend the slide-out.</i></p>
---	---	--

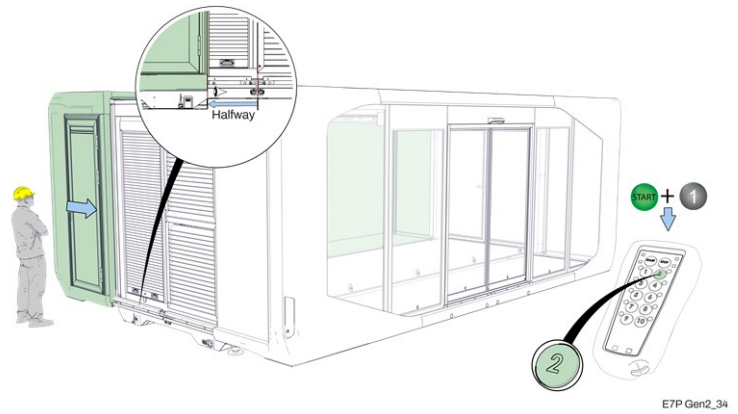
 Please refer to the important note below\*.



- Press the indicated button and retract the right slide out halfway.

		<p><i>While the right slide out is moving pay close attention to the sound and movement. Stop immediately if any deformation occurs during extension. Correct the cause of the deformation before continuing to extend the slide-out.</i></p>
---	---	---

 Please refer to the important note below\*.

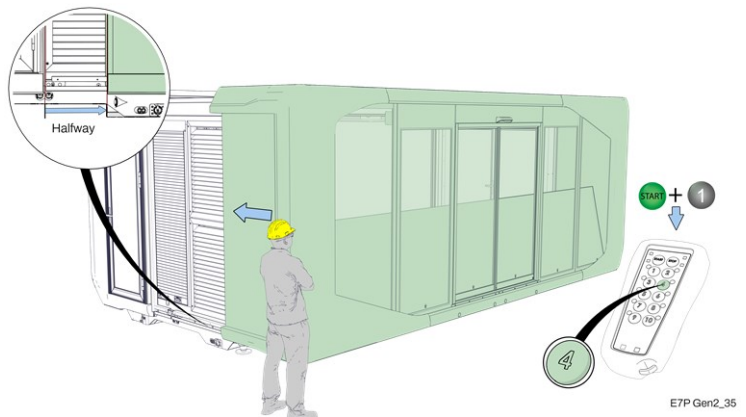

- Press the indicated remote control button to lift the container to its maximum height.

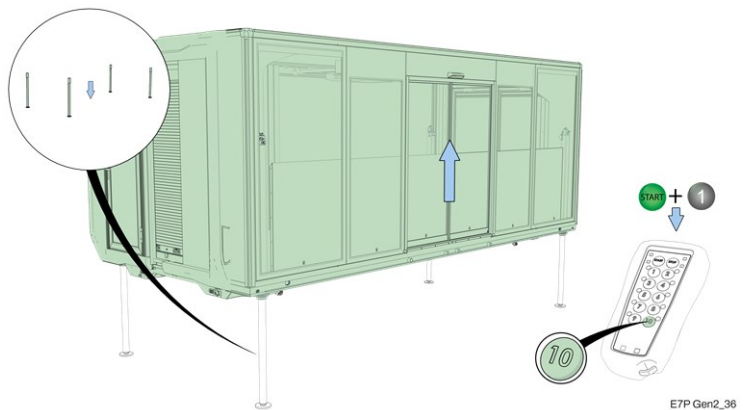

- Drive the truck combination under the Pod.

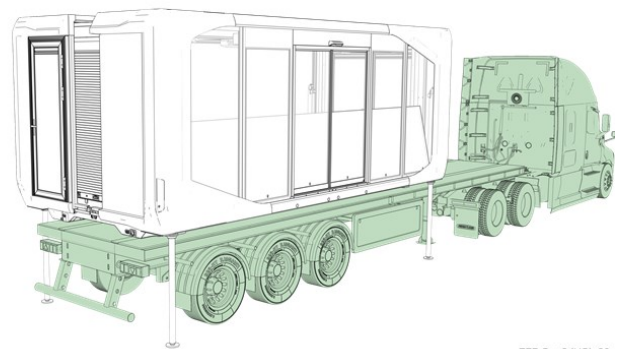

- 14. Press the indicated remote control button to lower the Expandable Pod onto the trailer.

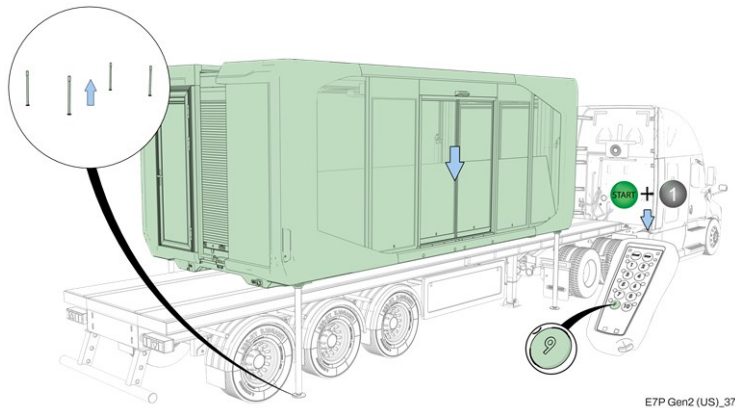

- 15. Press the indicated remote control button to fully retract the piston rods of the lift cylinders.

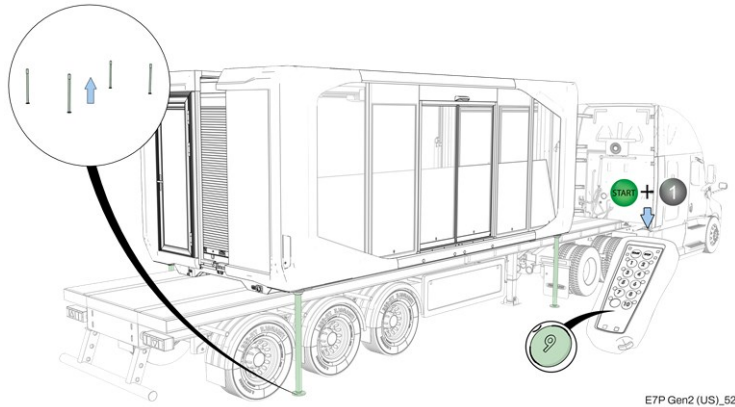

- 16. Press the indicated remote control button to fully retract the right lift cylinders.

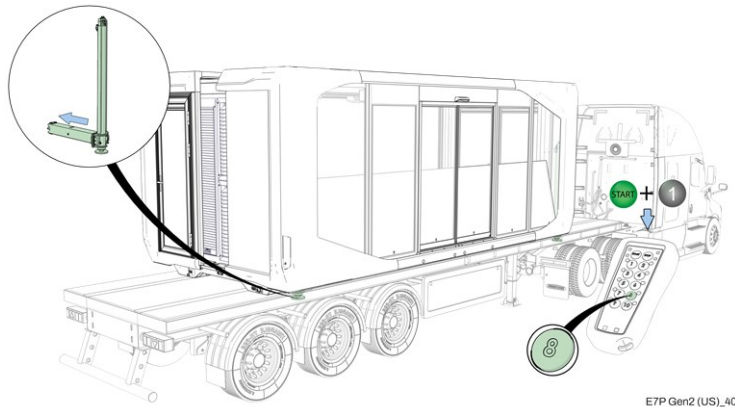

- 17. Press the indicated remote control button to fully retract the left lifting cylinders.

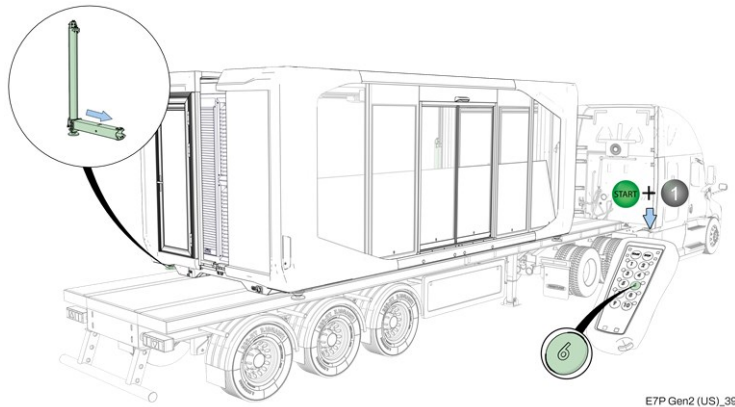

18. Press the indicated remote control button to fully retract the left slide out

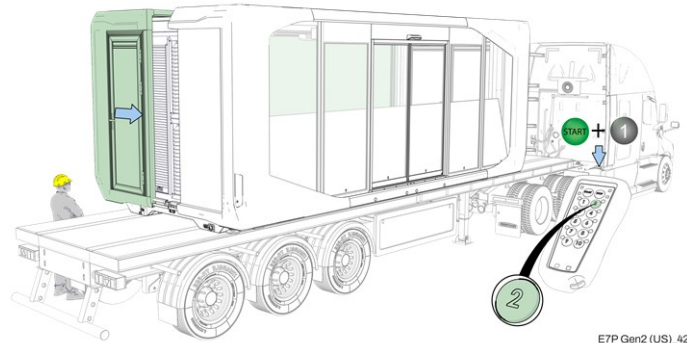

E7P Gen2 (US)\_42

19. Press the indicated remote control button to fully retract the right lifting cylinder.

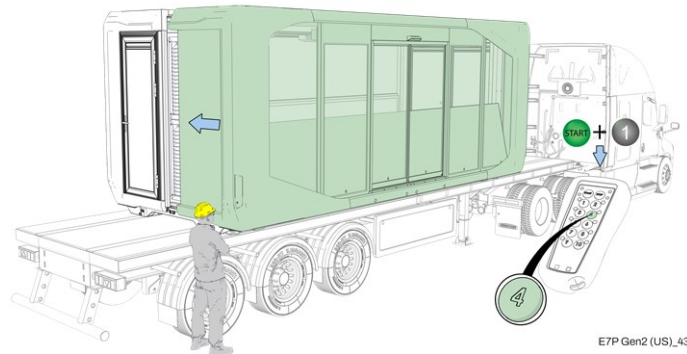

E7P Gen2 (US)\_43

20. Turn the battery disconnect switch to "OFF".

**⚠** *It is important to turn the main power off to the Pod. Failing to do so will allow the Pod to be operated while on the trailer. This can cause dangerous situations!!!*

21. Lock the main switch with a pad lock.

**⚠** *Prevent the Expandable Pod from being operated unintentionally!!!*

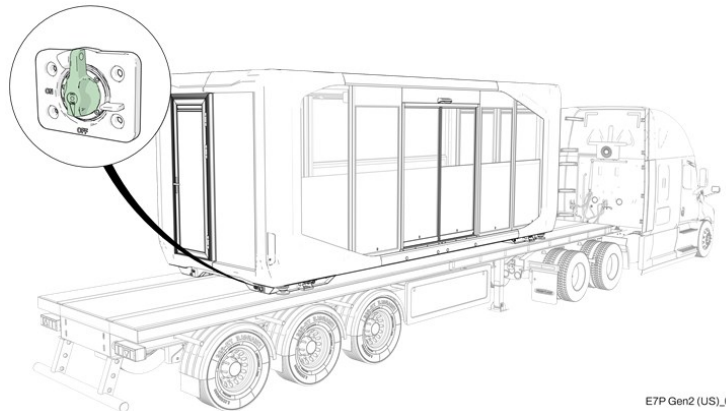

E7P Gen2 (US)\_04

22. Attach the pod to the Expandable Pod.

**⚠** *Use the lashing eyelets on the Expandable Pod chassis. Never route straps over the Expandable Pod. The slide-outs are made of polyester and cannot withstand the pressure created when the straps are tightened.*

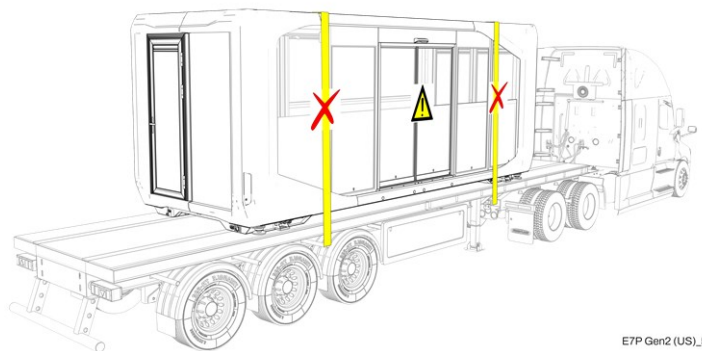

E7P Gen2 (US)\_53

*\*A safety feature ensures that the slide-out sections automatically stop before they can contact the lift cylinders (approximately halfway).*

## 6. Emergency Operation

This chapter provides information on how to access the Expandable Pod in case of a technical malfunction.

## 6.1 Accessibility Expandable Pod in case of malfunction

The Expandable Pod is accessible in most cases even in the event of a technical malfunction.

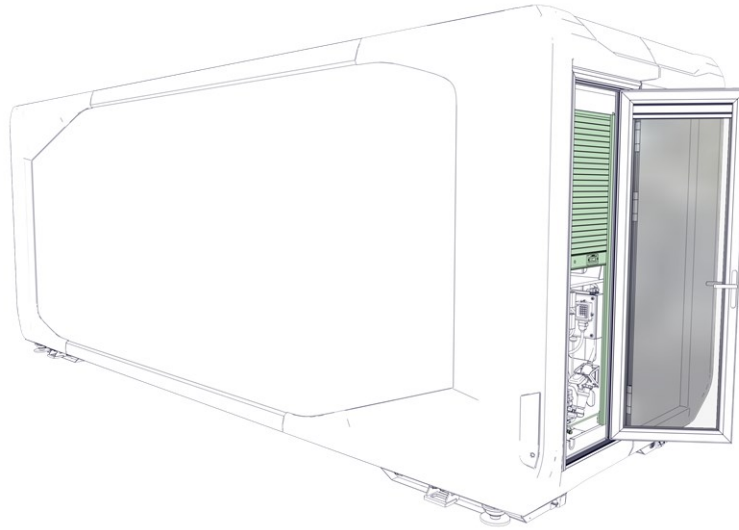

E7P Gen2\_51

Image 6-1

1. Unlock and open the door in the slide-out.
2. Unlock and open the roller shutter door.

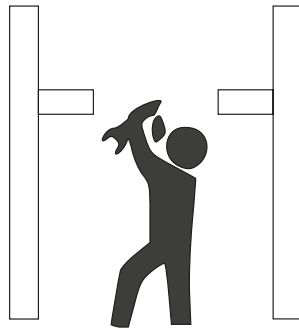

## 7. Periodic Maintenance

*In this chapter, you will find information about the maintenance that you must perform on your Expandable Pod. You will also find information about ordering parts.*

## 7.1 Maintenance Schedule

The table shown below lists the components that require periodic maintenance.

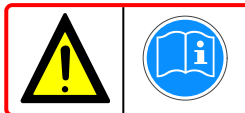

*Expandable LLC advises adhering to the maintenance intervals indicated in the table and using only products with the specified specifications. Order your required products from Expandable LLC (864)-400-5095 in a timely manner.*

Check	Work	Daily / Before use	Responsible Party
Sliding sleeves ③	Check for pollution / remove	x	Driver / Operator
Non-retractable Roof ①	Check for pollution / remove	x	Driver / Operator
Oil leakage	Check / Report	x	Driver / Operator
Hydraulic cylinders Lifting / Slide outs / Leveling ④ - ⑤	Check / Report	x	Driver / Operator
Door Locks	Check / Report	x	Driver / Operator
Battery Voltage ②	Check / Report	x	Driver / Operator
Body Damage	Check / Report	x	Driver / Operator
Service		Interval	
Expandable Service 1		2000 Km/ 2 Weeks	Service Workshop
Expandable Service 2		30.000 Km/ Every 3 Months	Service Workshop
Expandable Service 3		60.000 Km / Every 60 Months	Service Workshop
Expandable Service 4		120.000 Km / Every 12 Months	Service Workshop

Table 7-1 Maintenance Schedule

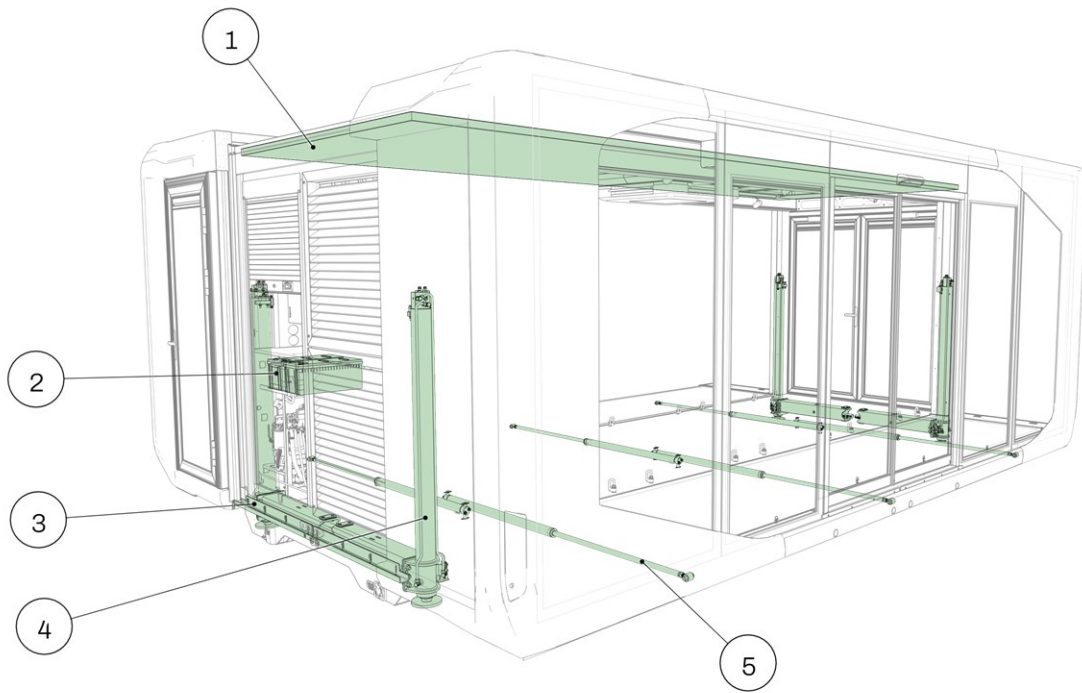

E7P Gen2\_61

Points of interest during daily maintenance

## 7.1.1 Oil Level

For proper functioning of the hydraulic system, it is essential that the oil is always at the correct level. To properly check the oil level, the following conditions must be met;

- *Make sure the Expandable Pod is level.*
- *Ensure that the slide-outs are fully retracted.*

### Procedure

Follow the procedure given below.

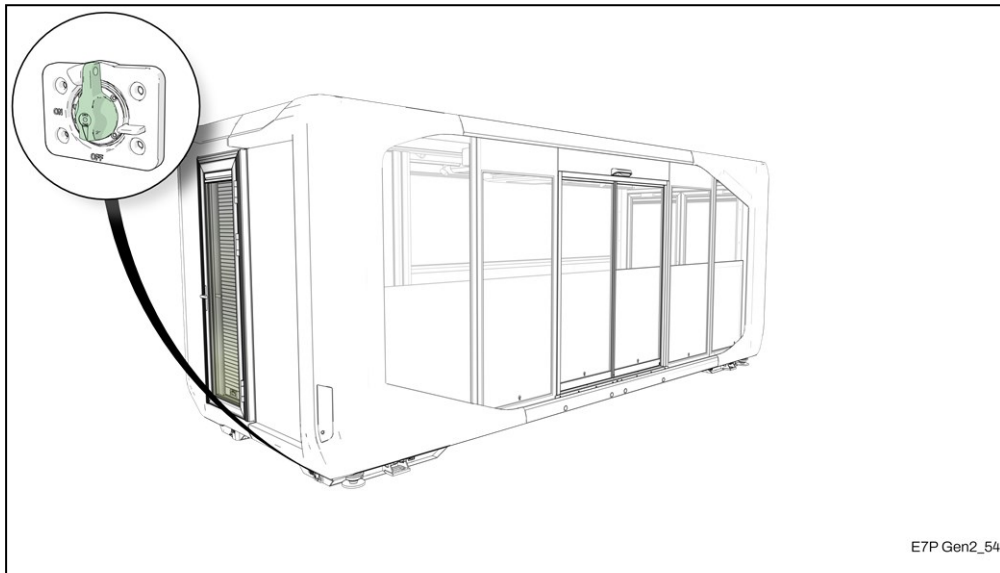

1. ↑ Turn the battery disconnect switch to the "ON" position.

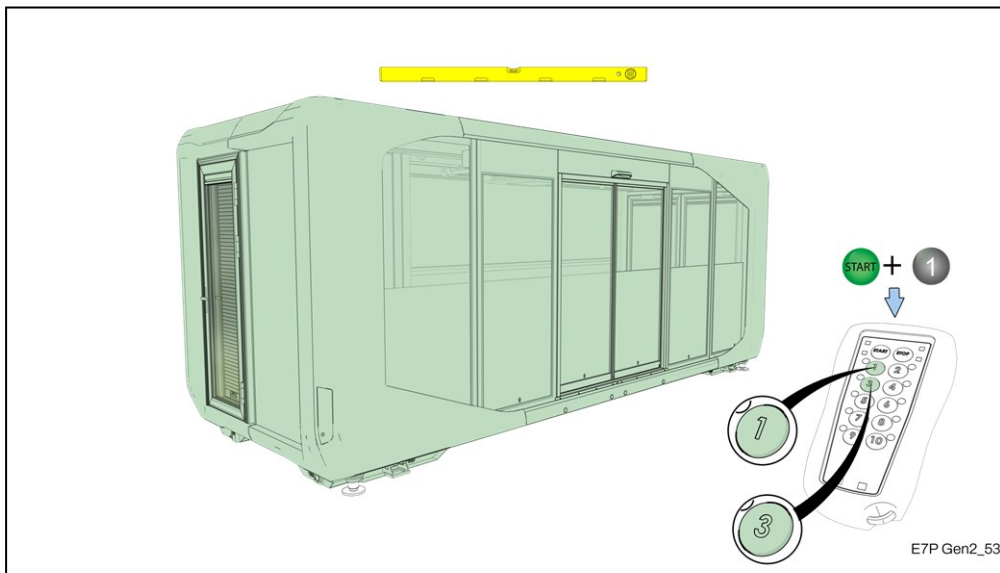

2. ↑ Press the indicated remote control buttons to level Expandable Pod.



*The piston rods must touch the ground before leveling.*

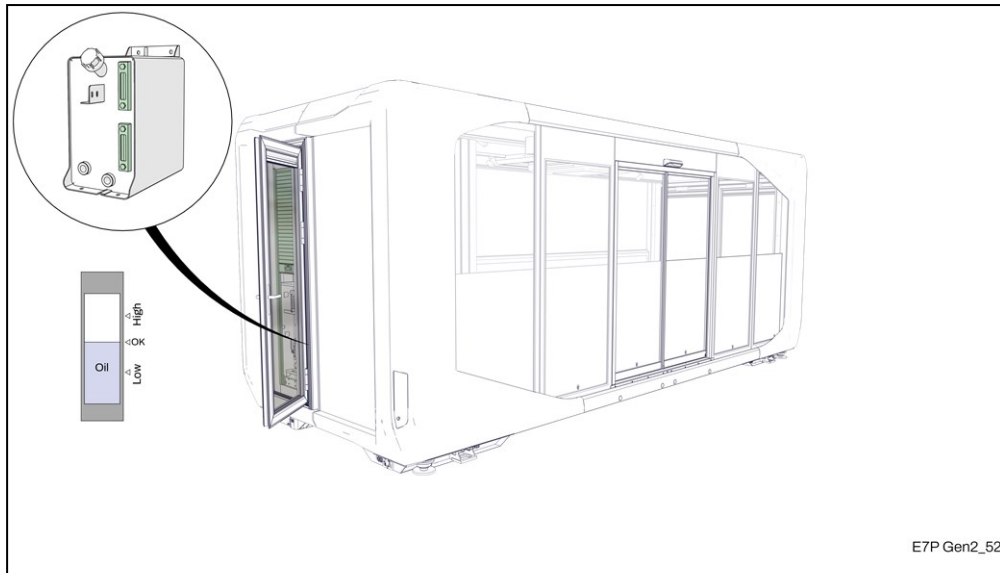

3. ↑ Open the access door and the roll-up door.
4. Ensure that the oil level is halfway up the upper sight glass. If necessary, refill the hydraulic oil (See "Oil refill on page 1")
5. Close and lock the roll-up door.
6. Turn the battery disconnect switch to the "OFF" position and secure it with a padlock.

## 7.1.1.1 Refilling Oil

When the hydraulic oil level is low, refill the system as required.



*Hydraulic oil can only be refilled through the roller shutter door of the technical area.*

### Procedure

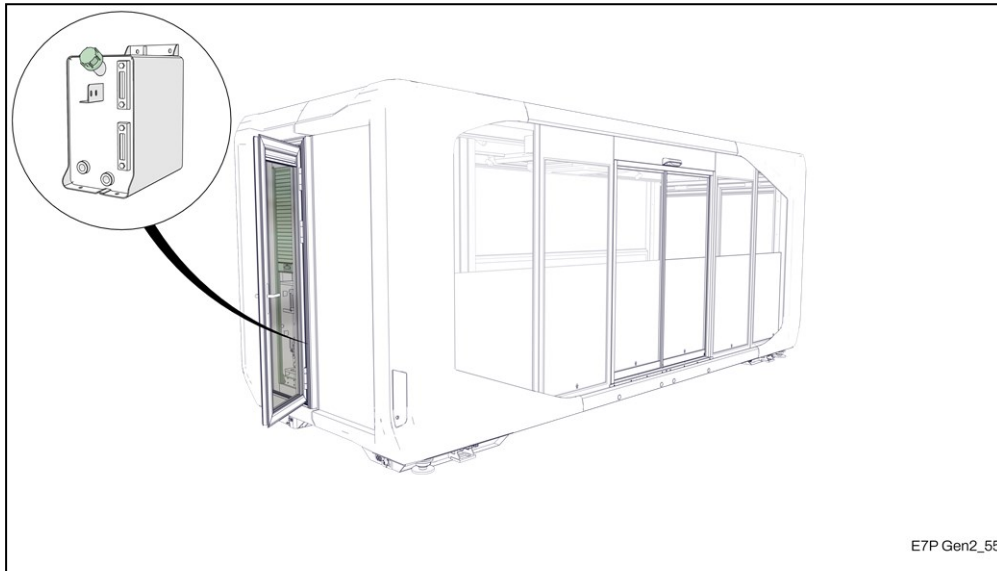

Follow the procedure given below.

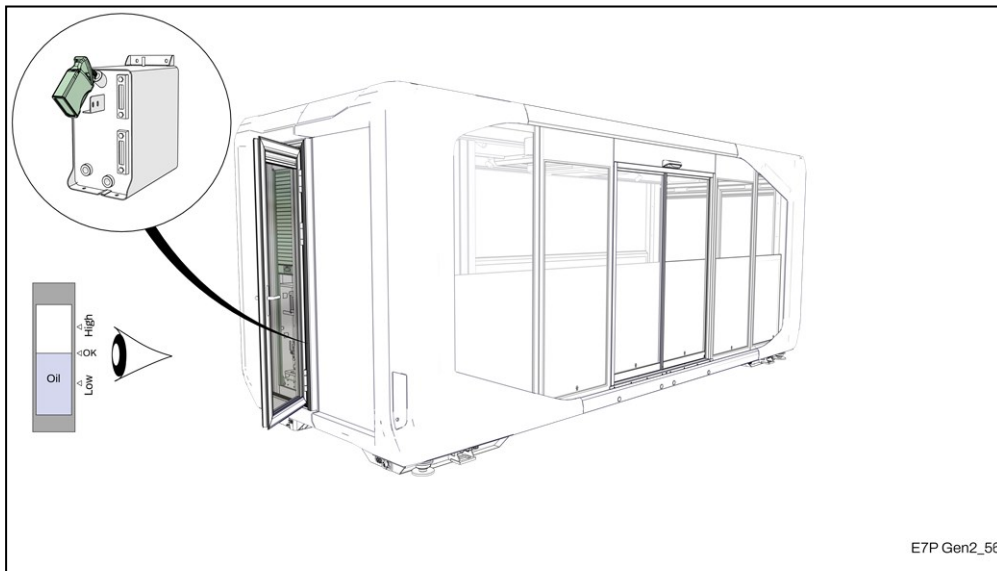

1. ↑ Remove the tank cap.



2. ↑ Refill the hydraulic oil (See "Maintenance Schedule on page 32") and check the level using the upper sight glass.

*To prevent damage to the hydraulic system and potential leaks, Expandable LLC recommends scheduling an appointment with an authorized service workshop if the hydraulic oil level is too high.*

3. Reinstall the tank cap and tighten it securely.

## 8. Safety & Environment

The following paragraphs contain information on the safe use of the Expandable Pod. It also describes how to act when the Expandable Pod has reached the end of its lifespan.

## 8.1 Environment

 When the Expandable Pod reaches the end of its life for any reason, it must be dismantled and disposed of according to local and/or national regulations.

Contact the local or national government service, the waste service, or the supplier where you purchased the product for more information regarding the locations where the materials are collected for recycling.

## 8.2 Safety During Use

 The use of a Expandable Pod can potentially bring risks.

Always consult the relevant regulations (for example: road traffic law, company procedures, safety and health regulations) that apply to the country where the Expandable Pod is used.

### General instructions for the use of a Expandable Pod:

- *Never set up the Expandable Pod on terrain where the slope exceeds the permitted values.*
- *Never use or place a Expandable Pod **NEVER** on public roads unless it has been established that the complete trailer complies with national road traffic legislation.*
- *Read the user manual **BEFORE** coupling and/or using a Expandable Pod.*
- *Perform the daily inspection **BEFORE** coupling and/or using a Expandable Pod.*
- *The truck driver is **ALWAYS** responsible for the use of a Expandable Pod.*
- *Only maneuver with the Expandable Pod if there are **NO** people or animals in the immediate vicinity of moving parts of the trailer.*

The nature of potential hazards and limitations during use are symbolized by the pictograms below.



## 9. General Information

The following paragraphs provide general information regarding this User manual and the product manufactured by Expandable LLC.

## 9.1 Cleaning

Use a mild detergent and remove the detergent with water from the hose at low pressure. Expandable LLC recommends NOT cleaning the Expandable Pod with aggressive or etching detergents. Using a pressure washer or cleaning in a car wash is strongly discouraged. This is to prevent loosening of the film from wrapped parts of the Expandable Pod.

## 9.2 Vehicle Registration and Delivery

 When a Expandable Pod is handed over to the customer, all associated documentation regarding the Expandable Pod must be provided to the customer.

 *The vehicle may not be used until it is established that the trailer on which the Expandable Pod is mounted complies with the national road traffic laws.*

 *The national road traffic laws are specific to each country. Contact the national inspection authority in the respective country for the required information.*

Subject	Action
Warning sticker	Check that the warning stickers are placed in such a way that they are clearly visible to the users.
User manual	The user manual for the Expandable Pod is handed over to the customer upon delivery. Indicate to the customer that the user manual should be kept with the Expandable Pod.
Warranty	Warranty on products from Expandable LLC can be found in the delivery terms.

Table 9-1 Delivery Documents

### 9.3 Site Conditions

Your Expandable Pod should preferably be made ready for use and transport on a site that is level both longitudinally and laterally. However, some slope of the site is allowed as long as the slope angles do not exceed the maximum permissible values shown in the table (see "Table 9-2"). The maximum allowable slope angles in both the longitudinal and lateral directions are shown below:

	Slope Angle
Longitudinal direction	2°
Lateral direction	3°

Table 9-2 Slope Angles

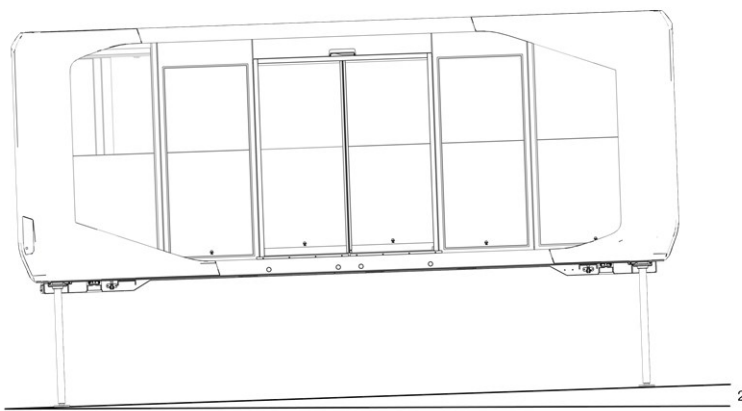

E7P Gen2\_49

*Maximum slope angle longitudinal direction*

Image 9-1

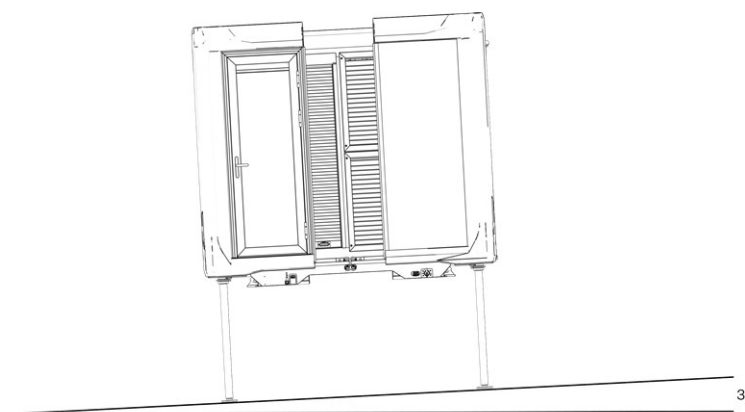

E7P Gen2\_50

*Maximum slope angle lateral direction*

Image 9-2

Before preparing the Expandable Pod for operation, always ensure that the site has sufficient load-bearing capacity to support the weight of the Expandable Pod and its interior. Use the supplied outrigger pads under the lift cylinders.

## 9.4 Access to the Technical Area

The technical area is located at the rear of the Expandable Pod and is normally accessible in both the transport and operational positions for minor repairs or diagnostics. In such cases, open the access door and the roll-up door. For more extensive repairs, such as condenser replacement, a panel inside the Expandable Pod may need to be removed.

In the technical area, you will find:

- *The air conditioning system*
- *The electrical system, including the batteries*
- *The hydraulic control system, including the pumps, tank, and filter*



**Repairs and diagnostics may only be performed by qualified technicians or, for simple tasks, under the guidance of authorized service personnel.**

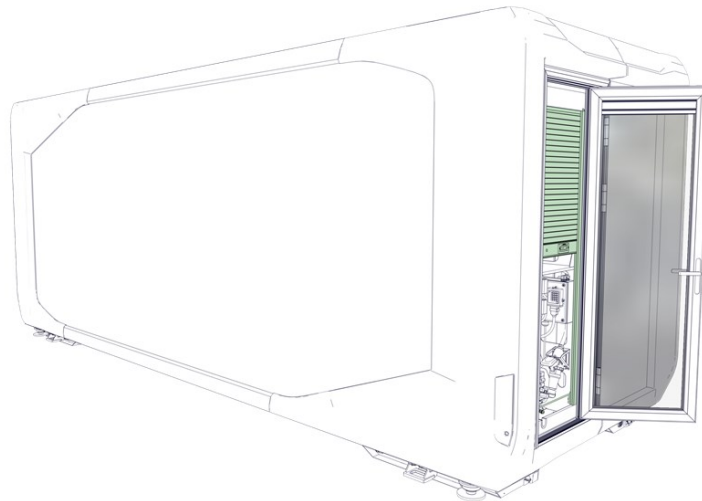

E7P Gen2\_51

### *Access to the technical area in transport position*

*Image 9-3*

In the image below, the positions of the main components in the technical area are shown.

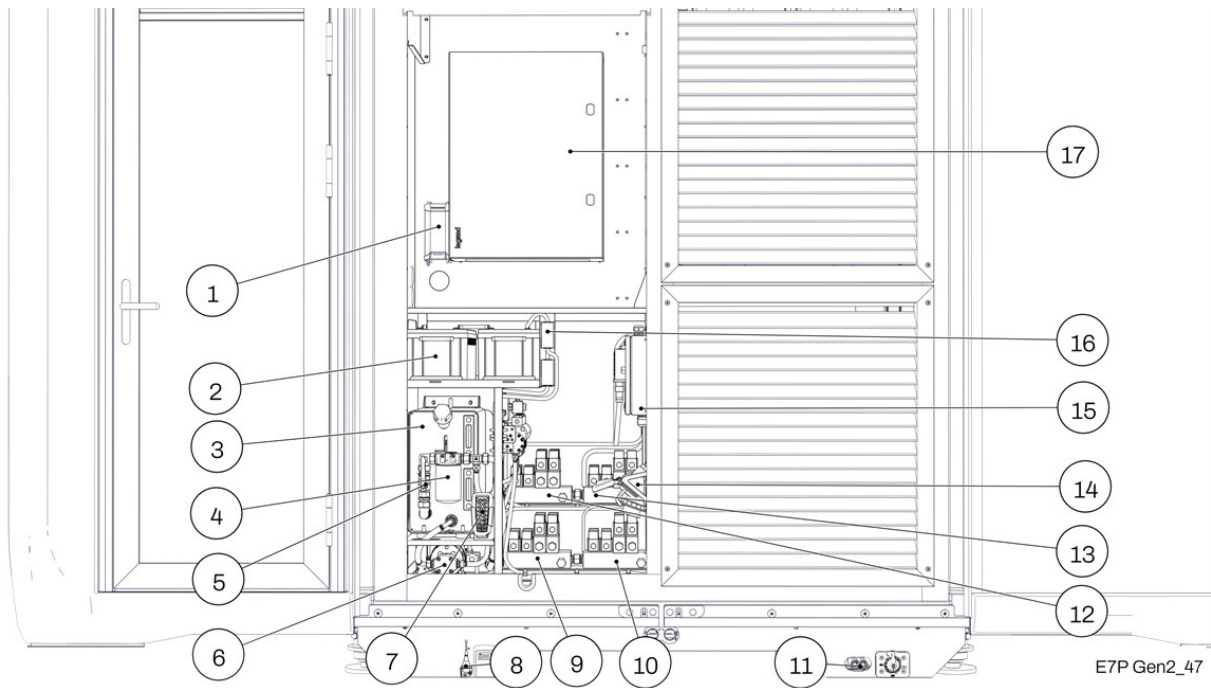

Image 9-4

- |  |                                    |
|--|------------------------------------|
| 1 Tickle charger                           | 10 Valve slide outs                |
| 2 Batties                                  | 11 Type Y connector                |
| 3 Hydraulic Oil Tank                       | 12 Valve slide outs                |
| 4 Oil filter                               | 13 Valve slide outs                |
| 5 Oil Shut-off Valve                       | 14 Shore Power Connection          |
| 6 Oil pump                                 | 15 Remote Control Receiver Control |
| 7 Remote control support                   | 16 Batterie fuses                  |
| 8 Remote Control Receiver Antenna          | 17 Electrical Control Cabinet      |
| 9 Valve Horizontal movement lift cylinders |                                    |

 *The hydraulic filter must be replaced periodically .*

## 9.5 Checking and Recharging Battery

The batteries are normally recharged via the built-in trickle charger when shore power is connected. The battery voltage can be checked at the battery terminals.

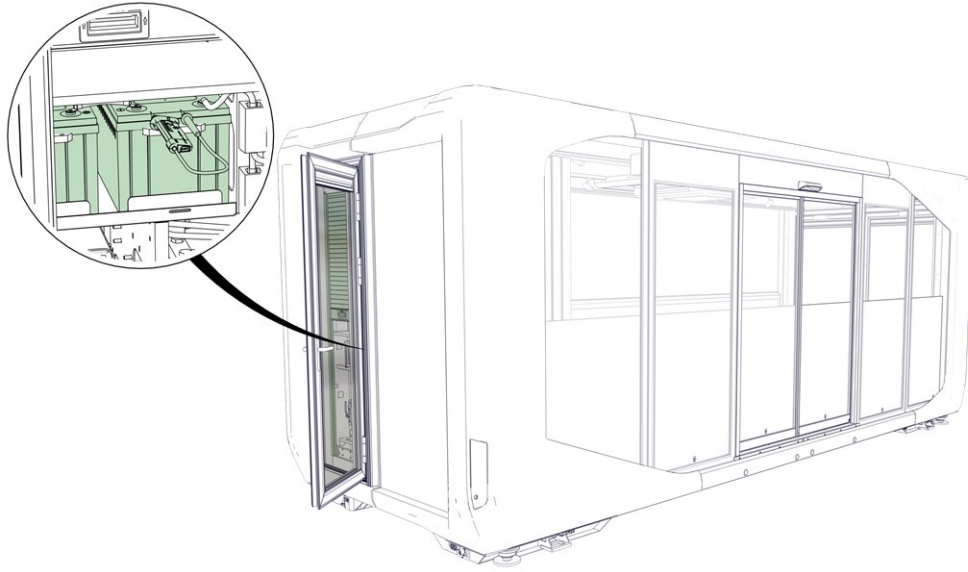

E7P Gen2\_58

*Image 9-5*

Should the voltage be too low, a charger can be connected to the type Y plug.

## 9.6 Stickers

Expandable LLC has placed stickers on your Expandable Pod at various locations. Never ignore these stickers. The stickers clarify the function of components or warn against improper use of the Expandable Pod.

Below is the meaning of the stickers.



*Image 9-6*

This sticker indicates that no people or animals are allowed inside the Expandable Pod during transport.



*Image 9-7*

This sticker is located on the step at the access door (if provided) and indicates that the step must be removed during road transport.

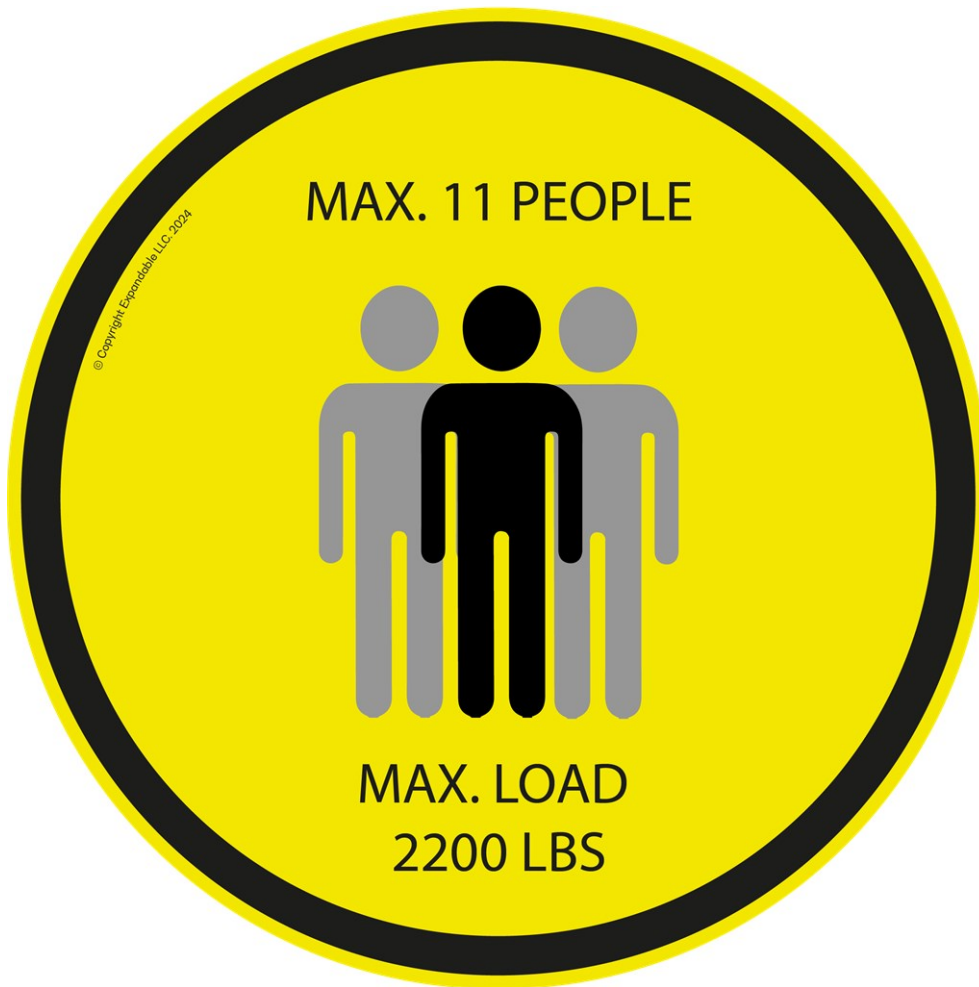

Image 9-8

If your Expandable Pod is equipped with an optionally available roof terrace, you will find the sticker shown above on the door to the roof terrace. This indicates that the maximum load of the roof terrace may be . This corresponds to people with an average weight of 185 lbs without any tables, chairs, and parasols, etc., that may be placed.

		<p><i>Stickers applied to theExpandable Pod by Expandable LLC may only be removed for replacement with new copies if they have become unreadable. Replace stickers before use if they are unreadable. Ordering: Dail (864)-400-5095</i></p>
--	--	---

## 9.6.1 Type Plate

The type plate shown below is affixed to the chassis of the Expandable Pod. This plate provides information about:

- The maximum load per axle
- The gross vehicle weight
- The VIN
- The Expandable Pod type
- the production date



<b>TYPE</b>	 <b>EXPANDABLE</b> <small>movable spaces</small>	Production number	
<b>E7P</b>		Month constr. Year constr.	dd-mm-yyyy
Manufacturer	<b>Expandable BV</b>	Length	<b>7560</b>
VIN	PRXXXX/E7P/DDMMYY	Width	<b>2550</b>
GROSS WEIGHT	<b>7000</b>	MAX. LOAD	<b>3500</b>

Image 9-9





*The type sticker must always be clearly legible. Replace the sticker as soon as it becomes unreadable. In that case, contact Expandable LLC at (864)-400-5095 to order a new sticker. The sticker may not be replaced by a sticker made by third parties without written permission from Expandable LLC*

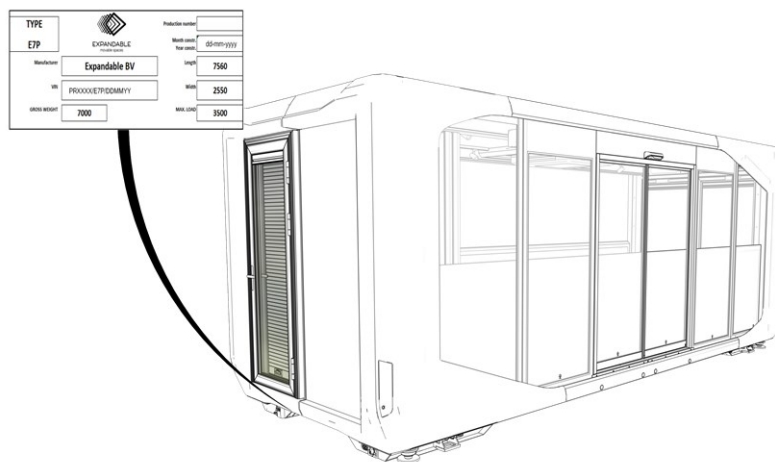

E7P Gen2\_59

Image 9-10

The type sticker is affixed to the inside of the right chassis beam.

*No changes may be made to the type sticker. Contact Expandable LLC at (864)-400-5095 if the type sticker has become unreadable.*

## 9.7 Pod Specifications

In the table below, the specifications for the "Expandable Pod" type 30ft are listed.

	30ft
Maximum weight	59524 lbs
Load capacity*	26455 lbs
External length (Transport)	approx. 31ft 4"
External length (Deployed)	approx. 31ft 4"
External width (Transport)	approx. 8ft 4"
External width (Deployed)	approx. 15ft 8"
External height (Transport)	approx. 9ft 8"
External height (Deployed)	approx. 9ft 8"
Internal surface area in transport position	approx. 182.98 sqft
Internal surface area in usage position	approx. 452.08 sqft
Internal volume in transport position	approx. 56 cu yd
Internal volume in usage position	approx. 115 cu yd
Maximum number of people on the roof when used as a roof terrace without equipment	15 (average 185 lbs per person)
Maximum load on middle roof	2860 lbs
Maximum weight per sqft when in transport position	11 lbs
Maximum weight per sqft when deployed	11 lbs

Table 9-3 Trailer Specifications

\* According to a specific loading schedule

## 9.8 Oil Specifications

Bosch Rexroth	RE 90220 notes	Eaton Brochure	03-410-2010
DIN	51517-2 CL	ISO	11158 HM
DIN	51524-2 HLP	MAG IAS	P-68, P-69, P-70
Dension	HF-0, HF-1, HF-2	Swedisch Standard	SS 115434 AM

Table 9-4 Oil Specifications

### 9.8.1 Oil Properties

	Method	Unit	Features
ISO viscosity class			32
Density, 15°C	D 4052	g/ml	0,87
Kinematic viscosity 40°C	D 445	mm <sup>2</sup> /s	32.2
Kinematic viscosity 100°C	D445	mm <sup>2</sup> /s	5.6
Viscosity Index	D 2270		111
Acid Number TAN	D 974	mg KOH/g	0.3
Solidification point	D 97	°C	-30
flashpoint, COC	D 92	°C	208
Emulsion, distilled water, 54.4°C	D 1401		40-40-0(10)
Foam, 5 min blowing, seq. 1/2/3	D 892	ml	5/10/5
c 1/2/3	D 892	ml	0/0/0
Anti-rust test, proc. A and B, 24h	D 665		pass
Copper strip, 3h, 100°C	D 130		1
FZG Test, A/8.3/90	DIN 51354	load stage	10

Table 9-5 The above figures are not a specification. They are typical figures obtained within production tolerances.

## 9.9 Lubricant Properties and Specifications

Berulub Lubricant Properties	
	Suitable for low temperatures
	Prevents stick-slip
	Extended relubrication intervals
	Very good adhesion
	Non-dripping and non-melting
	Resistant to hot and cold water, water vapors, lactic, formic, acetic or fruit acids as well as watery-alkaline and acid disinfecting or cleaning agents
	Contains PTFE

Table 9-6 Berulub Lubricant Properties

	Characteristics
Base oil	Ester
Thickener	Polytetrafluoroethylene (PTFE)
NLGI-grade	3
Kinematic viscosity at 104 °F	5000,0 mm <sup>2</sup> /s
Kinematic viscosity at 212 °F	340,0 mm <sup>2</sup> /s
Working temperature range	-4 °F up to 302 °F
Color/Appearance	White
Propellant	Dimethyl ether

Table 9-7 Characteristics

## 9.10 Electrical Component Specifications

Battery	Type	DC250-12 (12V250Ah)
	Capacity	250Ah@10hr-rate to 1.80V per cell @77 F
	Max. Discharge Current	2250A (5 sec)
	Normal Operating Temperature	77° F ± 5° F
	Recommended Maximum Charging Current	67.5A
Connection Voltage		24 V
Roller Current Connection		240 V ( 50 A split face)
Voltage Sockets		120 V
Light Switches		120 V
Fuses per Group		16 A
Electrical Components Hydraulics		24 V
Main Switch	Maximum Operating Voltage	48V, 32V DC & 12V DC single cycle: 48V DC
	Max. Continuous Current	5A-600 A
	Inrush Current (2 sec)	3,500 A
	Terminal Bolt Size	3/8"-16 (accepts M10 -connections)
	Moisture Ingress Protection	IP67/IP69K
	Ignition Protection	ISO 8846 & SAE J1171
Water Level Sensor	Moisture Ingress Protection	IP67, IP69K (with IP69K counter connector)
	Relative Humidity	0 - 95% (non-condensing, housing fully potted)
	Power Supply Voltage	10 - 32 V dc
	Polarity Protection	Yes
	Power Consumption	50mA For CFM models (CANbus in series): max. current internal T-joint: 2.5A
	Operating Temperature	-40 .. +176 °F
Inductive Sensor	Operating Voltage	7....30V
	Output Type	NPN
	Output Polarity	DC
	Ambient Temperature	-40 .. +176 °F
	Mass	45 g
	Protection	IP68 / IP69K
Hydraulic Pump	Operating Voltage	16 - 32 V
	Overvoltage	36 V (1 hour) / 48 V (5 min.)
	Reverse Operating Voltage	-16 V (1 hour) / -32 V (10 hours)

Table 9-8 Specifications of Electrical Components



*The specifications mentioned in the table above are a selection from the full specifications of the manufacturer. Expandable LLC always advises consulting the supplied documentation of the manufacturer of the electrical components, which supersedes anything related in this manual.*

## 9.11 Pictograms

The following pictograms are used in this manual:

















Description		Description		Description	
	Important announcement!		Maximum number of people / maximum load		Delivery information.
	Risk of entrapment!		Read this information before you start!		Parts information.
	Error		Risk of damage to the system!		Information regarding daily use!
	Wear safety shoes		Wear head protection		Conditions set by Expandable LLC
	Wear work gloves		Wear safety clothing		Surface treatment
	Wear hearing protection		Wear safety glasses		Good

Table 9-9 Pictograms

## Notes

## Notes

**any questions?**  
contact us

**Expandable LLC**  
7021 Augusta Road  
Piedmont  
SC, 29673  
United States

(864)-400-5095  
info@expandable-usa.com



**EXPANDABLE**  
movable spaces

Part no.: 162039 EN (US)-0  
Release: 02-2026

[www.expandable-trailers.com](http://www.expandable-trailers.com)