

**create
space**
and never
forget

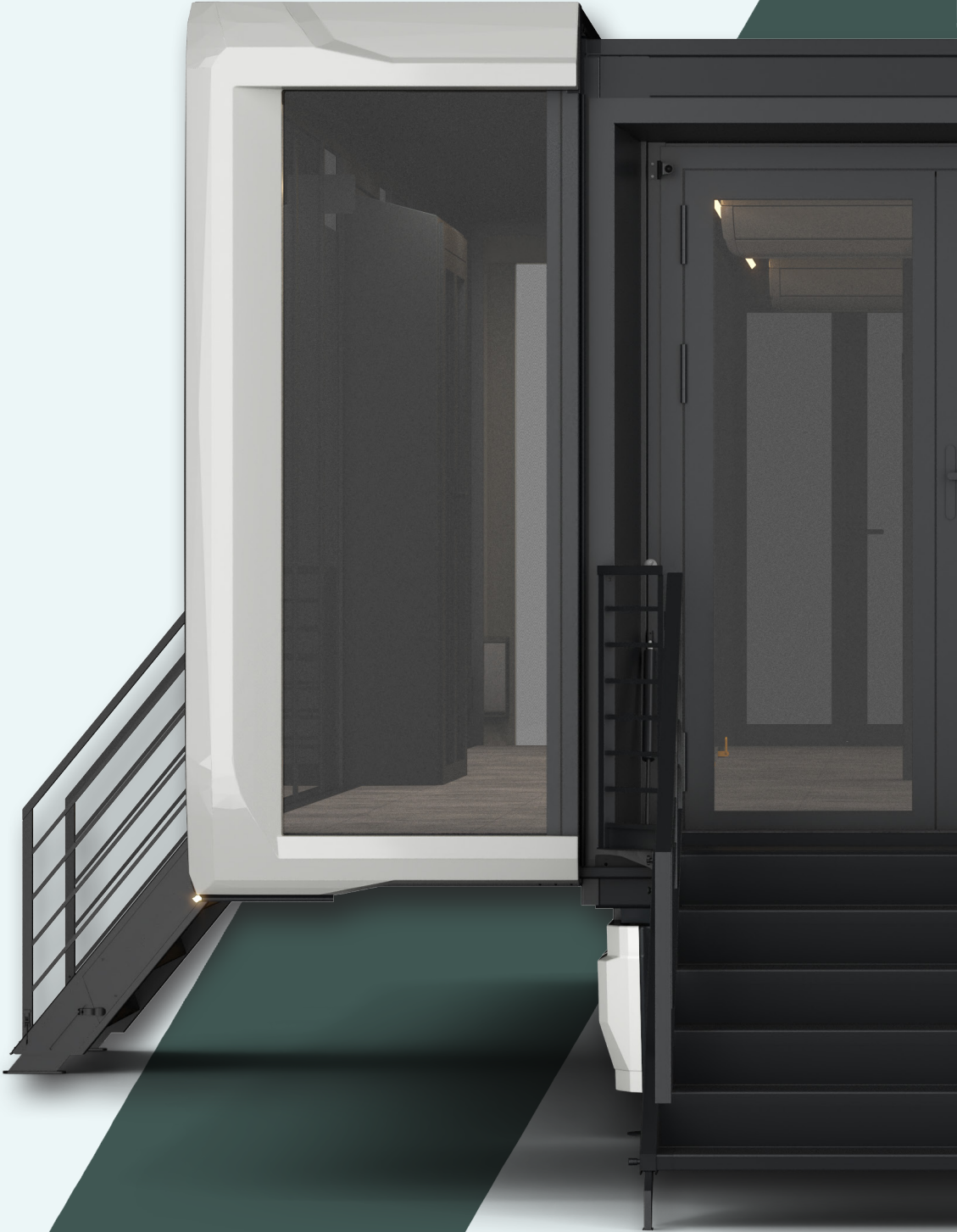

EXPANDABLE
movable spaces

User manual
TRAILER
44FT

Table of contents

1. Description	2
1.1 Expandable 44ft Trailer	3
1.1.1 Hydraulic and Electrical Control System	4
1.1.2 Commissioning and Preparing for Transport	6
1.1.3 Accessories and Batteries	7
1.1.4 Shore Power Connection	8
1.1.5 Key Safe	8
1.1.6 Front Connections Expandable 44ft Trailer	9
1.1.7 Tire Pressure Monitoring System(TPMS)	10
2. Remote Control	13
2.1 Remote Control Expandable 44ft Trailer	14
2.2 Switching On the Remote Control	17
2.3 Switching Off the Remote Control	19
2.4 Settings	20
2.4.1 Main menu	20
2.4.1.1 User menu	21
2.4.1.1.1 Menu "Display"	22
2.4.1.1.2 Warnings	23
2.4.1.1.3 Language	24
2.4.1.2 Settings	25
2.4.1.2.1 Koppelen AB	26
2.4.1.3 Sensor Information	29
2.5 Operation	31
3. Preparing the Expandable 44ft Trailer for Use	32
3.1 Preparing the Expandable 44ft Trailer for Use	33
4. Commissioning	37
4.1 Connecting Shore Power	38
4.2 Power Shutdown	39
5. Preparing the Expandable 44ft Trailer for Transport	40
5.1 Preparation for transport	41
5.2 Vacuum Collapse of the Air Bellows	46

6. Periodic Maintenance	48
6.1 Maintenance Schedule	49
6.2 Oil level	53
6.2.1 Refilling Oil	55
7. Safety & Environment	58
7.1 Environment	60
7.2 Safety During Use	60
8. General Information	61
8.1 Cleaning	62
8.2 Vehicle Registration and Delivery	63
8.3 Terrain Conditions	65
8.4 Checking and Recharging Battery Voltage	67
8.5 VIN Plate and ALR Plate	68
8.6 Expandable 44ft Trailer Specifications	70
8.7 Oil Specifications	71
8.7.1 Oil Properties	71
8.8 Properties and Specifications of Lubricant	72
8.9 Specifications of Electrical Components	73
8.10 Pictograms	75

Foreword

 This manual is intended for drivers and/or other users of the Expandable 44ft Trailer and contains the necessary information on use. This owner's manual should always be kept with the vehicle. A separate maintenance and repair manual is available for service technicians via the website: www.expandable-trailers.com.

Purposeful use:

An Expandable 44ft Trailer is designed for independent use. Modifications of any any kind can affect the safety of the system. Both the warranty on Expandable B.V. products and the homologation are void as soon as these products are modified without Expandable B.V.'s written consent. When the Expandable 44ft Trailer is not used according to the instructions given by Expandable B.V. used, all warranty claims against Expandable B.V. or suppliers of the Expandable 44ft Trailer will be invalidated. Before putting the system into use, it must be established that the trailer complies with nationally applicable road traffic legislation. The system may only be put into put into service in accordance with the tractor and trailer manuals. manuals of the trailer.

The illustrations in this manual serve as examples only and are not intended for any other purpose. Images shown may differ slightly from the delivered system.



All safety information is described in the relevant chapter (See "Safety & Environment on page 58"). In the remaining chapters, safety risks are symbolised using pictograms.

Contact information

Expandable B.V.
Meerheide 25
Eersel 5521DZ Eersel
The Netherlands
Tel: +31 (0)85 890 21 88
www.expandable-trailers.com
info@expandable.nl

Validity and copyright:

No part of this document may be reproduced and/or published by printing, photocopying, microfilm, or any other means without written permission from Expandable B.V. The images and specifications have been compiled with great care, but we cannot accept any liability for any deviations. Expandable B.V. reserves the right to make technical changes to parts without prior notice. For information on this subject, please contact Expandable B.V.

© Copyright Expandable B.V., Eersel, The Netherlands
Date of issue: 31/03/2026 Original version: 1.0

1. Description

This chapter describes the Expandable 44ft Trailer. Here you will find information about the naming of components and their functions.

1.1 Expandable 44ft Trailer

Main components

An Expandable 44ft Trailer is a semi-trailer with hydraulically extendable sections (segments), allowing the volume to be increased approximately 2x. The Expandable 44ft Trailer has 8 walls whose panels can be chosen by the customer. One has a choice of door panels, glass walls, stairs and closed panels.

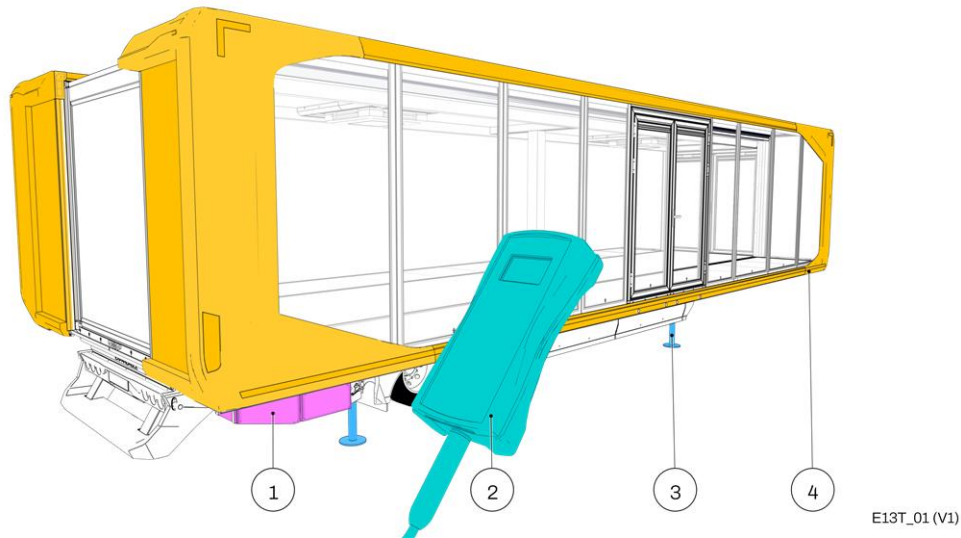

Fig. 1-1

- | | |
|-------------------|--|
| 1 Storage Cabinet | 3 Lifting Cylinders |
| 2 Remote control | 4 Slide out (retractable and extendable) |

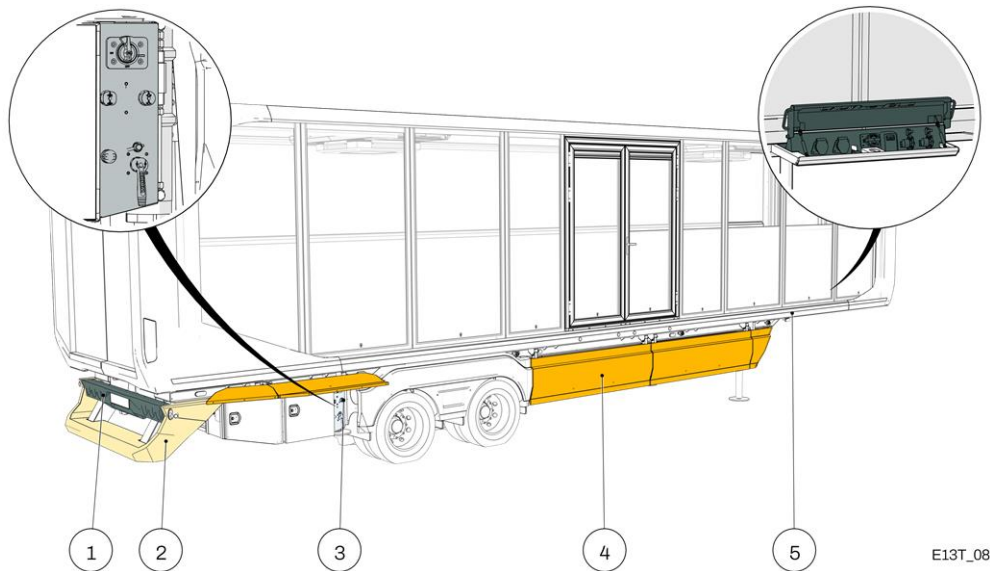

Fig. 1-2

- | | |
|----------------------------|-----------------------------|
| 1. Rear Lighting Bar | 4. Crash Protection |
| 2. Bumper | 5. Tractor Unit Connections |
| 3. Hydro-Pneumatic Control | |

The crash protections can be folded upwards, providing access to the storage compartments and the controls of the hydraulic system.

1.1.1 Hydraulic and Electrical Control System

In the left storage compartment on the right-hand rear side, beneath the Expandable 44ft Trailer, you'll find components for the Electro-Hydraulic System.

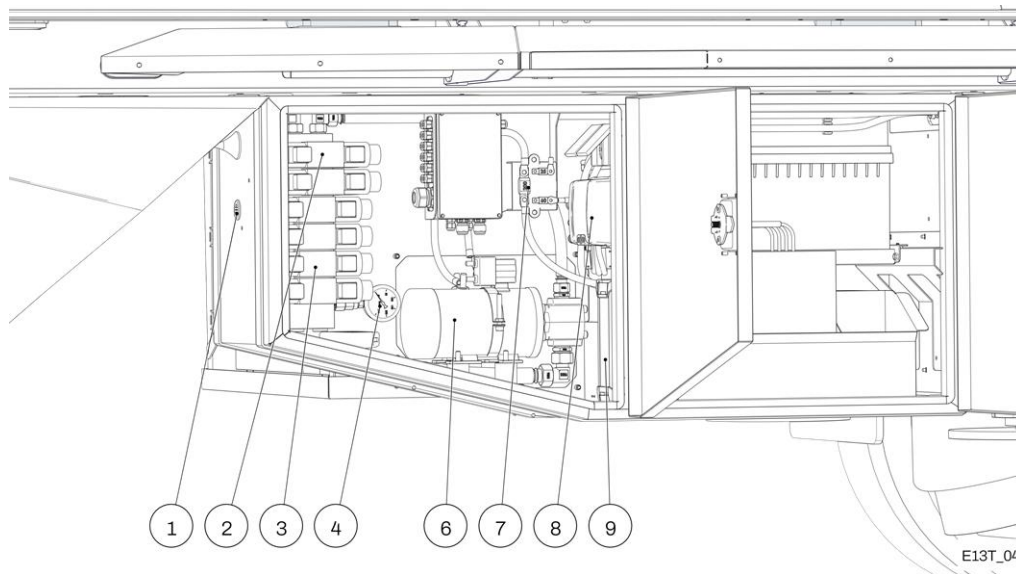

Fig. 1-3

1. Leveling System Buzzer	6. Hydraulic Pump
2. Valve manifolds slide-outs	7. Charging fuse, pump fuse, and control cabinet
3. Valves for the Hydraulic Lift Cylinders	8. DC-DC Converter
4. Pressure Gauge	9. Trickle Charger
5. Hydraulic Control Cabinet	

1. Buzzer

The buzzer of the leveling system emits a signal once the leveling procedure of the Expandable 44ft Trailer has been successfully completed. At that moment, the trailer is level in both directions.

2. Valve Manifolds for the Slide-outs

These valve manifolds control the inward and outward movement of the slide-outs once one of the corresponding buttons on the remote control have been pressed. (See ["Remote control Expandable 44ft Trailer on page 1"](#)).

3. Valve for the Hydraulic Lift Cylinder

This valve controls the inward and outward movement of the piston rod in a hydraulic lift cylinder once one of the corresponding buttons on the remote control have been pressed.

4. Pressure Gauge

The pressure in the hydraulic system can be read on the pressure gauge when one or more cylinders are being operated, such as those for the slide-outs or the lift cylinders.

5. Hydraulic Control Cabinet

The coils, which are operated via the remote control, are energised through the control cabinet.

6. Hydraulic Pump

The hydraulic pump converts mechanical energy into hydraulic power. By pressurising and directing hydraulic oil through an energised valve within a closed system, the piston rod will begin to move.

7. Charging fuse, pump fuse, and control cabinet

These fuses protect the charging system, the hydraulic pump, and the control cabinet against electrical overload.

8. DC-DC Converter

A DC-DC converter converts direct current (DC) from one voltage level to another. The

DC-DC converter regulates the charging voltage to a maximum of 28 V and limits the charging current to 17 A.

9. **Trickle Charger**

The trickle charger maintains the charge of both 12 V batteries when the Expandable 44ft Trailer is connected to shore power and has been disconnected from the tractor unit.

1.1.2 Commissioning and Preparing for Transport

To prepare the Expandable 44ft Trailer for use or for transport, both the remote control and the buttons on the Expandable 44ft Trailer, as well as the air control valve for the air suspension, are used. Normally, these buttons and the air control valve are operated when the tractor unit is coupled and the air system is connected to the tractor unit. However, it is also possible to use these buttons and the air control valve when the air supply in the air tanks is sufficient, even when the tractor unit is not coupled.

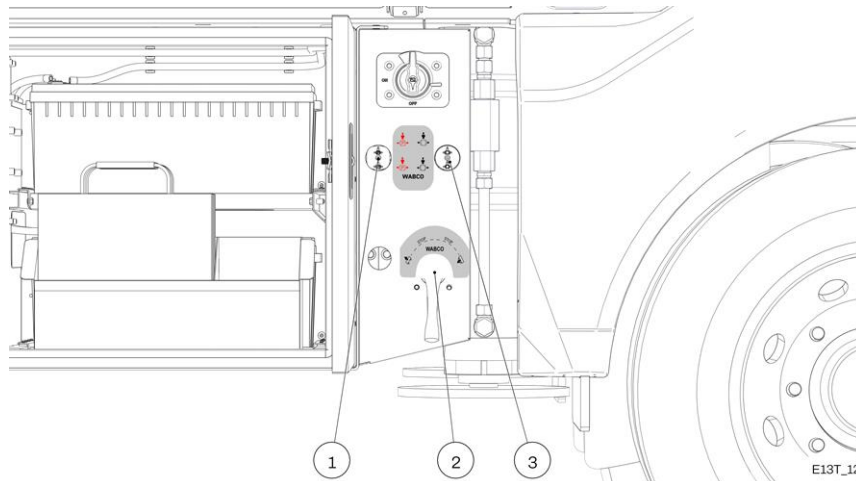

1. Parking Brake Button

2. Air Suspension Control Valve

3. Service Brake Button

1. Parking Brake Button

When the button is pushed **IN**, the parking brake is released. When the button is pulled **OUT**, the parking brake is applied.

2. Air Suspension Control Valve

If the air suspension control valve is turned clockwise, the air pressure in the air bellows is released. As a result, the Expandable 44ft Trailer lowers at the rear. When the valve is turned fully anticlockwise, the pressure in the bellows increases and the rear of the trailer rises. This only works when there is sufficient air pressure in the tanks. If necessary, couple the tractor unit. When the air suspension control valve is set to the mid-position, the Expandable 44ft Trailer returns to the preset ride height.

3. Service Brake Button

When the button is pushed **IN**, the service brake is released. When the button is pulled **OUT**, the service brake is applied.

1.1.3 Accessories and Batteries

The Expandable 44ft Trailer is equipped with a wireless system for commissioning and preparing the trailer for transport. This system uses a remote control and a receiver with an additional antenna. A spare remote control is also included on board.

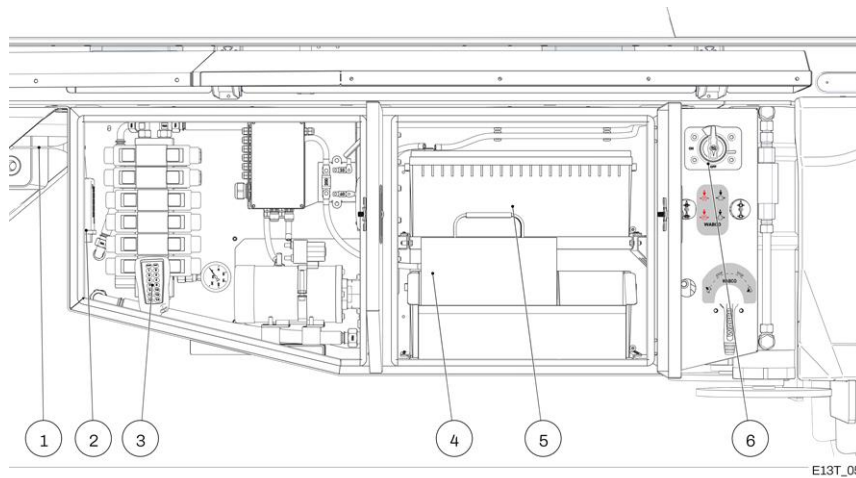

- | | |
|----------------------------|--------------------------|
| 1. Antenna | 4. Outrigger Plates |
| 2. Remote Control Receiver | 5. Batteries |
| 3. Remote Control | 6. Battery Master Switch |

Expandable B.V. strongly recommends using the supplied outrigger plates when preparing the Expandable 44ft Trailer for use.

1. These distribute the pressure of the outriggers over a larger surface area and reduce the risk of damage to the ground.
2. It is important that the ground is sufficiently load-bearing to prevent the trailer from sinking.
3. Once the battery master switch has been turned to the “ON” position, the 24 V hydraulic system becomes active.

1.1.4 Shore Power Connection

The power supply for all 240 V accessories (such as lighting, sockets) is provided via the shore power connection. The extension cable required for this connection is stored in the left-rear storage compartment beneath the Expandable 44ft Trailer floor.

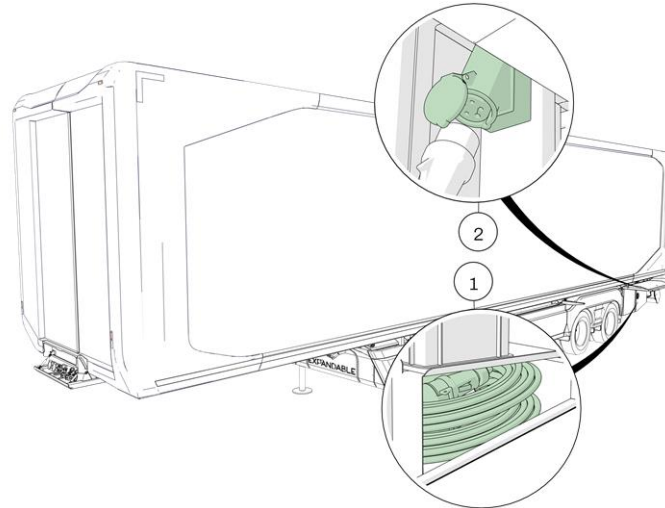

E13T_06

Fig. 1-4

1. Extension cable

2. Shore Power Connection

The extension cable can be connected to the shore power supply via the socket on the left-hand rear side of the Expandable 44ft Trailer.

1.1.5 Key Safe

The Expandable 44ft Trailer is equipped with a key safe. It is located beneath the flap at the front of the Expandable 44ft Trailer (see "Fig. 1-5"). The key safe is protected with a configurable code. The keys for the access doors can be stored inside the key safe so that they can always be kept close to the Expandable 44ft Trailer.

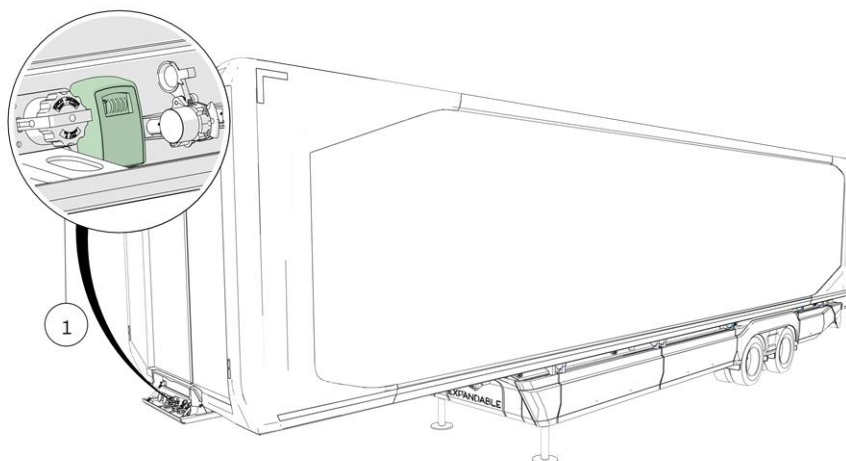

E13T_09

Fig. 1-5

1. Key Safe

1.1.6 Front Connections Expandable 44ft Trailer

At the front of the Expandable 44ft Trailerr, several electrical and pneumatic connections are located.

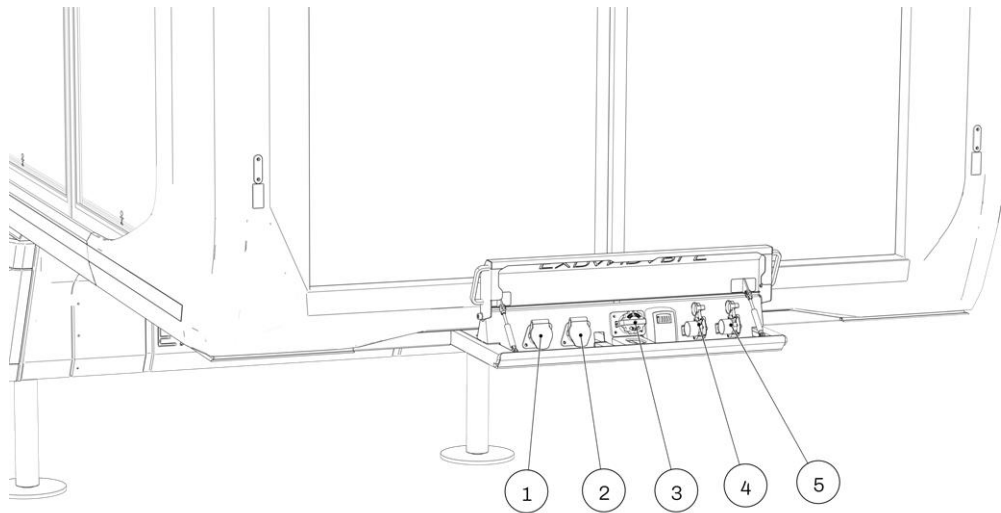

E13T_10

Fig. 1-6

1. 15-pin Socket
2. 7-pin Socket
3. NATO Socket

4. Air Connection (Red)
5. Air Connection (Yellow)

① 15-pin Socket

Through the 15-pin socket, the Expandable 44ft Trailer's basic lighting - such as indicators, tail lights, brake lights, rear fog light, and earth connection - is connected to the tractor unit.

② 7-pin Socket

The 7-pin ABS socket has the primary function of ensuring that the tractor unit and the Expandable 44ft Trailer brake evenly.

③ NATO Socket

The NATO socket allows the tractor unit to charge the batteries on board the trailer.

④ Red Air Connection ("Emergency Line")

Through the red air connection (emergency line), the Expandable 44ft Trailer's air tanks are supplied with air by the compressor of the tractor unit.

⑤ Yellow Air Connection ("Service Line")

Through this connection (service line), the braking command is transmitted from the tractor unit to the Expandable 44ft Trailer by means of air pressure.

1.1.7 Tire Pressure Monitoring System(TPMS)

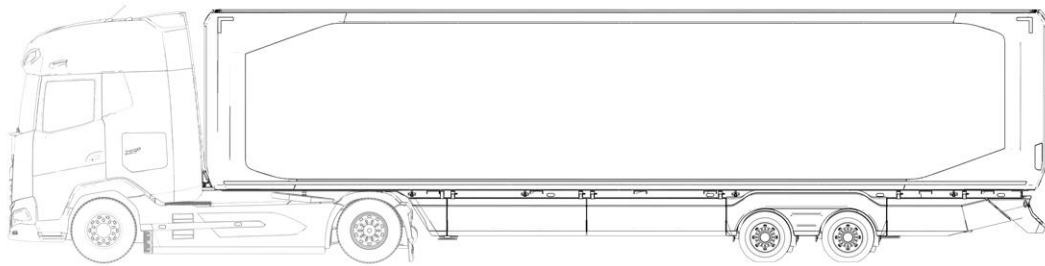

E13T_61

This Expandable 44ft Trailer is equipped with an electronic TPMS system. TPMS stands for Tyre Pressure Monitoring System. In a TPMS installation fitted by Expandable B.V., the sensor mounted inside the tyre (secured around the rim with a band) continuously measures both the tyre pressure and temperature. Each sensor transmits a unique wireless signal for its respective wheel, which can be received by a dedicated TPMS receiver. Several TPMS receivers are installed at various locations on the Expandable 44ft Trailer to ensure that these signals can be reliably transmitted to the tractor unit.

The main components consist of:

- A TPMS transmitter ①
- A TPMS receiver ②
- Mounting Band (for securing the TPMS sensor to the rim) ③

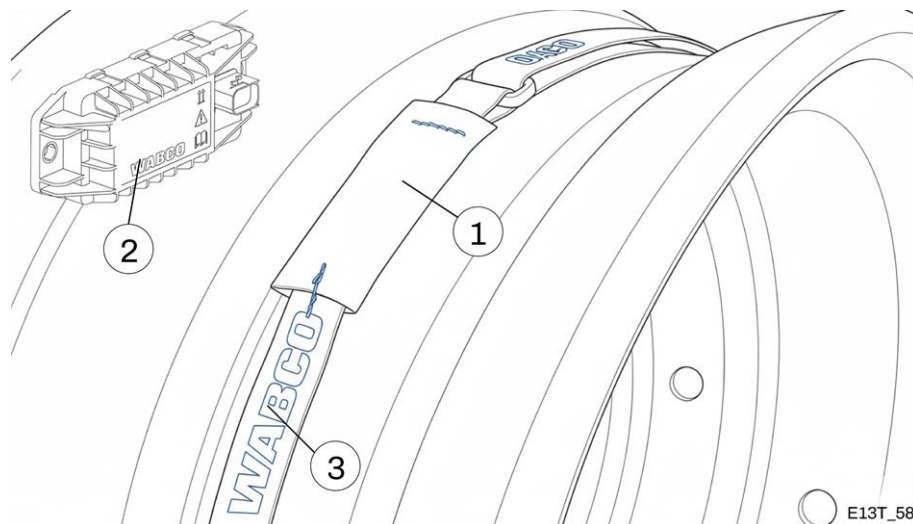

The TPMS system used on the Expandable 44ft Trailer complies with UN ECE-R 141 and ensures that the driver is warned in time if tyre pressure becomes too low. The tractor unit must, of course, be equipped with a compatible TPMS receiver system. In this way, potential accidents can be prevented. The TPMS system also has a positive effect on the energy consumption of the tractor unit.

Important Notes Regarding TPMS

Your Expandable 44ft Trailer uses ZF's OptiTire system. TPMS increases the safety of the trailer.



TPMS kan onvoldoende bandenspanning of onjuist bandenonderhoud niet compenseren.

To ensure proper operation of the TPMS (OptiTire) system, the tractor unit must meet the following requirements:

- *The tractor unit must be equipped with a compatible TPMS receiving system capable of processing the wireless signals sent by the TPMS sensors on the trailer.*
- *The tractor unit's electrical connection to the trailer must be fully operational, as the TPMS receivers on the trailer rely on a stable power supply.*
- *The tractor unit must support the communication protocol specified by ZF's OptiTire system (as applicable to the vehicle type and model).*
- *The tractor unit's onboard display or monitoring system must be configured to show TPMS warnings, pressure values, and temperature information to the driver.*
- *Any software updates recommended by the manufacturer should be installed to guarantee full compatibility with the OptiTire system.*

An electronic system monitors components both before and during driving. On electronic control units (ECUs) with power supply according to ISO 7638, the low tyre pressure/fault indicator light illuminates when the tractor unit's ignition is switched on. It should extinguish again once the vehicle combination is in motion. If the indicator light illuminates while driving, this indicates that the TPMS has detected a fault or low tyre pressure. The symbol for low tyre pressure or a potential TPMS fault complies with the current version of UN ECE Regulations R141/121 and appears as follows:



E13T_59

If the warning light illuminates, there is an increased risk of wheel damage while driving. For electronic systems with a power supply in accordance with ISO 7638, the driver must monitor the warning symbol each time the tractor unit's ignition is switched on. The symbol must illuminate and then extinguish when the vehicle begins to move (or, if the vehicle is already in motion, after one second). If the symbol does not illuminate, the warning system may be malfunctioning and immediate action should be taken. In such a situation, follow the steps below:

Procedure

1. Bring all tyres to the correct pressure (See "Tyre pressure (cold) on page 70")
2. Replace the suspected wheel with a spare wheel.
3. Disconnect the plug from socket ① and reconnect it to reset the system.

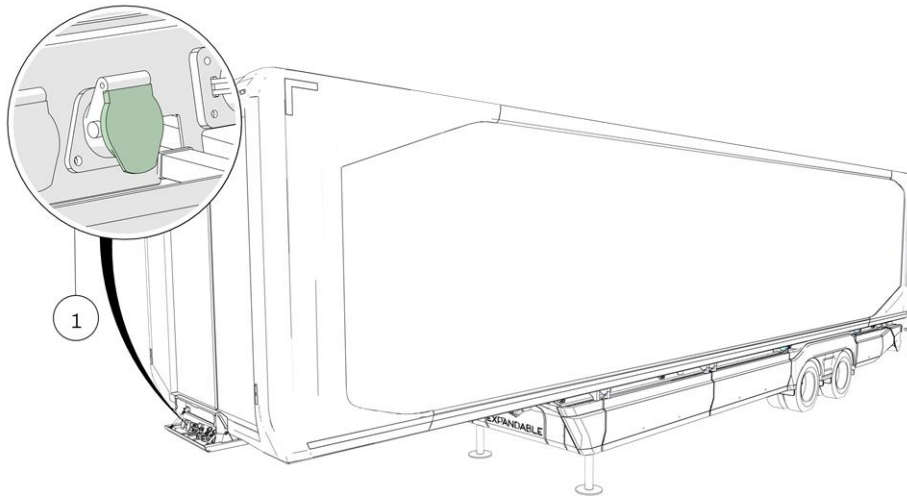

E13T_60

If the problem is not resolved, the TPMS must be checked immediately at a service station to identify and correct the fault(s). Furthermore, Expandable B.V. recommends that the operation of the TPMS be checked regularly as part of routine maintenance and during scheduled service intervals of both the tractor unit and the Expandable 44ft Trailer. All work on the TPMS may only be carried out by authorised personnel.

Safety Device

If the TPMS system is not functioning correctly or becomes inoperative, the Expandable 44ft Trailer can still be driven, but the tyre pressure will no longer be monitored.

		<i>The ABS spiral cable (ISO 7638) between the tractor unit and the Expandable 44ft Trailer must always be connected. Check this!</i>
		<i>If the TPMS system is not functioning correctly, contact an authorised Expandable B.V. service centre as soon as possible. Adjusting or configuring a TPMS without the proper experience is not possible!!!</i>
		<i>The Expandable 44ft Trailer itself is not equipped with a reset function. Resetting must therefore be carried out from the tractor unit. Please refer to the tractor unit's manual for the correct procedure.</i>

2. Remote Control

This chapter describes the remote control and the function of the buttons.

2.1 Remote Control Expandable 44ft Trailer



P-21936_18



The remote control is located in the storage compartment behind the crash protection on the right-hand rear side underneath the Expandable 44ft Trailer.

From model year 2026, the Expandable 44ft Trailer will be supplied with a new remote control system developed by Expandable B.V.. The system consists of two identical units which, depending on how they are paired, can function either as a transmitter or as a receiver. Both units are equipped with a cable connection. The cable can be connected to either of the units and to the control cabinet. When connected in this way, the unit will function as a receiver once it has been paired with a transmitter (remote control).

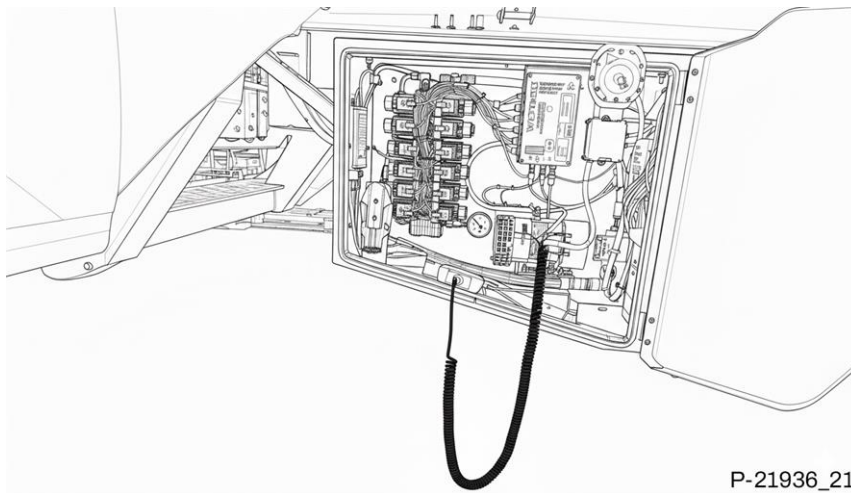

P-21936_21

If the transmitter is defective or not paired, the receiver will function as a remote control. In this case, the Expandable 44ft Trailer can be operated via the cable.

Layout

The control interface is divided into two sections. The upper section is used for settings, and the lower section is used for operating the Expandable 44ft Trailer.



P-21936_17

Settings



P-21936_19

Operation

2.2 Switching On the Remote Control

To operate the Expandable 44ft Trailer, the following conditions must be met:

- One of the two devices must be connected to the control cabinet via a cable.
- The battery master switch must be turned to the “ON” position.

1. Press and hold the button .
After a short time, the screen shown below will appear.



P-21936_19

2. The hydraulic functions of the Expandable 44ft Trailer can now be operated, and the remote control can be configured.



P-21936_01

Message “Not Connected”

If the transmitter is not connected to the receiver, the message shown below will appear on the display.



P-21936_08

This situation can normally have two causes:

- *The battery master switch is set to the “OFF” position.*
- *The transmitter and receiver are not paired.*

2.3 Switching Off the Remote Control

1. Press and hold the button .
After a short time, the screen shown below will appear.



P-21938_19

2. Press the button  to switch off the remote control.



P-21938_10

2.4 Settings



The buttons for the settings menu are yellow in colour.

2.4.1 Main menu



The indicator next to the letter "A" on the display is flashing.

In the Main Menu, the following sub menus are available:

- *User menu*
- *Settings menu*
- *Sensorinformation*

1. Press the button  to select the indicator.

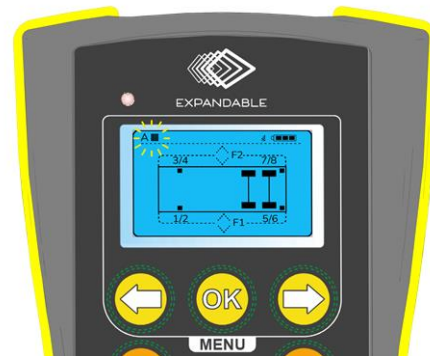

P-21936_20

2. Press the button  so that the main menu becomes visible.



P-21936_02

2.4.1.1 User menu

In the main menu, the following sub menus are available:

- *User menu*
- *Settings*
- *Sensor information*

Procedure

1. In the main menu, press the button  to select the “User Menu”.



P-21936_02

2. Press the button  so that the “User Menu” becomes visible.



P-21936_22

2.4.1.1.1 Menu "Display"

In the "Display" menu, the following settings are available:

- *Auto*
- *Brightness*
- *Standby (min)*
- *Auto shut off (min)*

Auto

With "Auto", the brightness of the display is automatically adjusted to the ambient light level. The selectable options are "Yes" or "No".

Brightness



Here, a fixed value for the display brightness can be set. The adjustable values range from 1 to 10. The "Auto" setting is then ignored.

Standby

Here, the time after which the display switches off can be set. The adjustable values range from 1 to 30 minutes. The default value is 1 minute.





Shutdown

Here, the time after which the remote control switches off once standby mode has been activated can be set. The adjustable values range from 1 to 30 minutes. The default value is 1 minute.

1. In the "User Menu", press the button  to select the "Display" menu and press the button  to confirm.



P-21936_22

2. In the "Display" menu, press the button  to select one of the available settings and press the button  to confirm. Set the desired value. The value can be adjusted using the buttons  or .



P-21936_03

2.4.1.1.2 Warnings

In the “Warnings” menu, the following settings are available:



- *Key Tone*
- *Warnings*

Key Tone

With “Key Tone”, you can set whether an audible signal is emitted when the buttons are operated. The available options are “Yes” or “No”.





Warnings

With “Warnings”, you can set whether an audible warning signal is emitted during operation. The available options are “Yes” or “No”

1. In the “User Menu”, press the button  to select the “Warnings” menu and press the button  to confirm.



P-21936_22

2. In the “Warnings” menu, press the button  to select one of the available settings and press the button  to confirm. Set the desired value. The value can be adjusted using the buttons  or .





P-21936_23

2.4.1.1.3 Language



In the “Language” menu, the following settings are available:

- *English*
- *Nederlands*
- *Deutsch*
- *Francais*

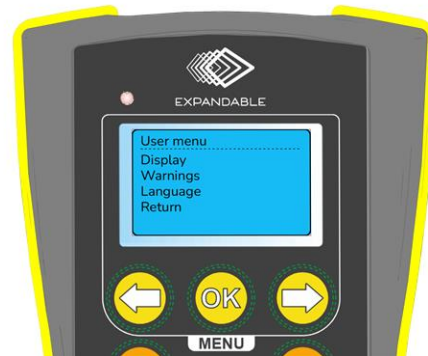
1. In the “User Menu”, press the button  to select the “Language” menu and press the button  to confirm.



P-21936_22

2. In the “Language” menu, press the button  to select the desired language and press the button  to confirm.





P-21936_18

2.4.1.2 Settings

To access the “Settings” menu from the main menu, an access code must be entered.



In this menu, you will have access to the following sub menu:

- *Pairing AB*

1. In the main menu, press the button  to select the “Settings Menu” press the button  to confirm.





P-21936_02

2. Press the button  so that the input field for the access code becomes visible.
3. Enter the access code and press the button  to confirm.



P-21936_09

4. In “Pair AB” menu, press the button  to select the “Pair” menu and press the button  to confirm.



P-21936_24

2.4.1.2.1 Koppelen AB

Status

In the “Status” menu, you can find information about which receiver the transmitter is paired with.

1. In the “Pairing AB” menu, press the button  to select “Status”.



P-21938_24

2. Press the button  to view the code of the receiver to which the transmitter is paired.

 *If no code is displayed, the device is not paired.*



P-21938_07

Pairing

As soon as you select the “Pairing” setting, the transmitter will start searching for the receiver. On the receiver, “Pairing” must also be selected and confirmed with OK in the “Pairing AB” menu, so that both devices can search for each other via Bluetooth.

1. In “Pair AB” menu, press the button  to select the “Pair” menu.



P-21936_24

2. Press the button . The devices to be paired will now start searching for each other.

 In the “Status” menu, the code of the paired device can be viewed. (See “Status on the previous page”).



P-21936_06

Reset

De koppeling tussen de zender en ontvanger kan verbroken worden, door in het menu "Koppelen AB" de functie "Terugzetten" te selecteren en deze vervolgens te bevestigen.

1. In "Pair AB" menu, press the button  to select the "Reset" menu.



P-21936_24

2. Press the button .
The devices are now unpaired.



P-21936_05

2.4.1.3 Sensor Information

The “Sensor Information” menu consists of five pages. These pages provide information on the following:

- *PLC software version*
- *Installed receiver software version (firmware)*
- *Installed transmitter software version (firmware)*
- *Position of the left slide-out*
- *Position of the right slide-out*
- *Outriggers*
- *Fault codes*
- *Trailer type*

1. In the main menu, press the button  to select the “Sensor Information” menu.



P-21938_02

2. Press the button  to go to the first page of the sensor information.

Batt.hydr.:

SW remote: Remote control software version code.

SW receiver: Receiver software version code.
b



P-21938_11

3. Press the button  in the Sensorinformation menu to go to the second page of the sensor information.

Tilt fr x: Front tilt X-axis

Tilt fr y: Front tilt Y-axis

Tilt rr x:Rear tilt X-axis

Tilt rr y: Rear tilt Y-axis

Pos.seg.L: Position of the left slide-out



P-21938_12

- Press the button  in the Sensorinformation menu to go to the third page of the sensor information.

Pos.seg.R: Position of the right slide-out



P-21938_13

- Press the button  in the Sensorinformation menu to go to the fourth page of the sensor information.



P-21938_14

2.5 Operation

In the operating area of the remote control, the buttons are located that allow control of the cylinders connected to the movable parts of the Expandable 44ft Trailer.

Button	Function	Description
	Trailer left front down	Retract piston rod
	Trailer left front up	Extend piston rod
	Trailer right front down	Retract piston rod
	Trailer right front up	Extend piston rod
	Trailer left rear down	Retract piston rod
	Trailer left rear up	Extend piston rod
	Trailer right rear down	Retract piston rod
	Trailer right rear up	Extend piston rod
	Auto level	Automatic Levelling
	Not active	
	Extend left slide-out	F1
	Retract left slide-out	F1
	Extend right slide-out	F2
	Retract right slide-out	F2

Table 2-1 Key functions

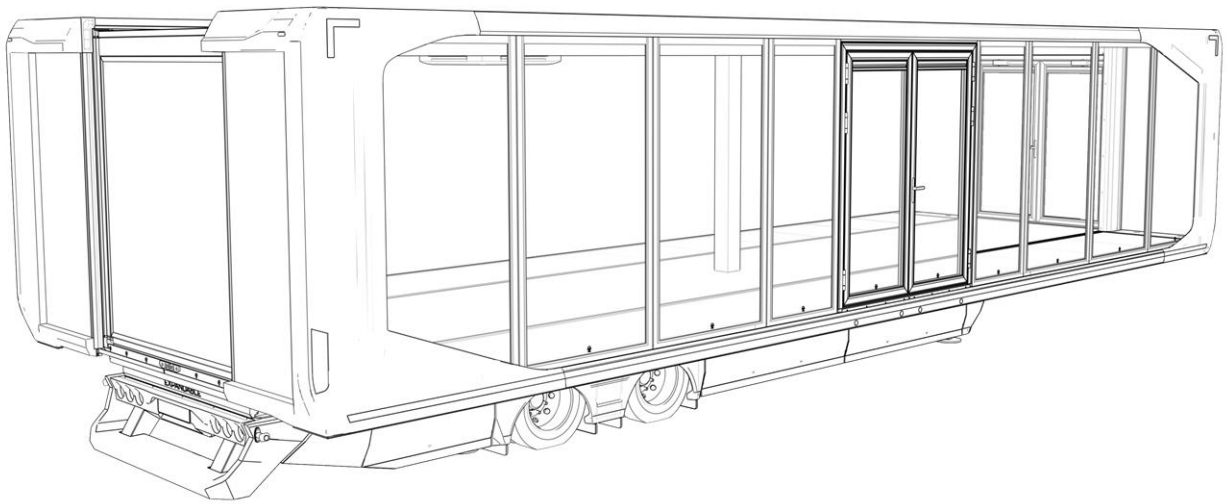

E13T_62

3. Preparing the Expandable 44ft Trailer for Use

In this chapter, you will find information on disconnecting the Expandable 44ft Trailer and preparing it for use.

3.1 Preparing the Expandable 44ft Trailer for Use

Follow the procedure below.

1. Disconnect the yellow and red air couplings.

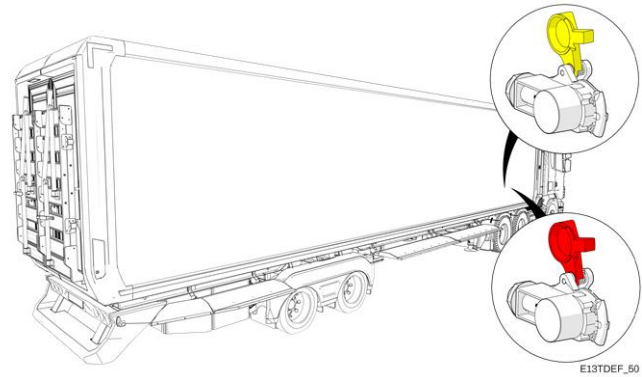

2. Unlock the crash protection on both the left and right sides and tilt it upwards.

		<i>Each section of the crash protection has two latches.</i>
--	--	--

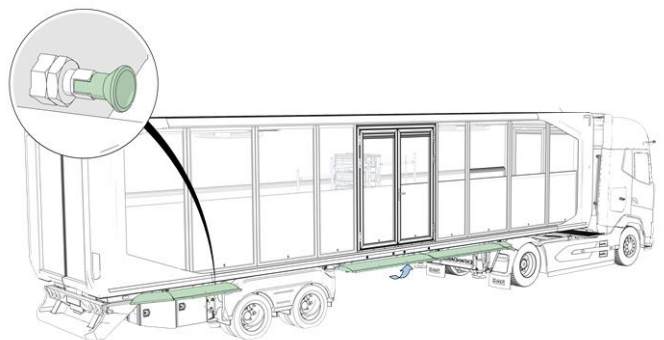



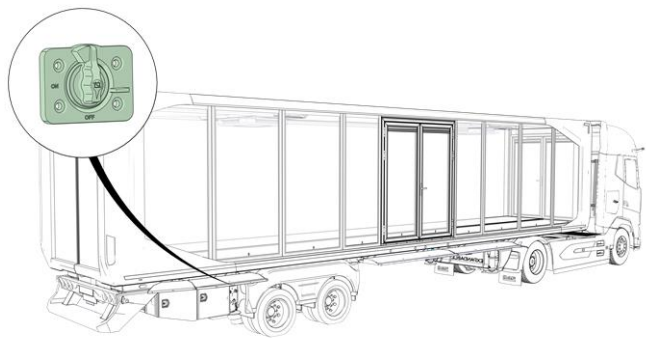

3. Turn the battery master switch to the "ON" position.

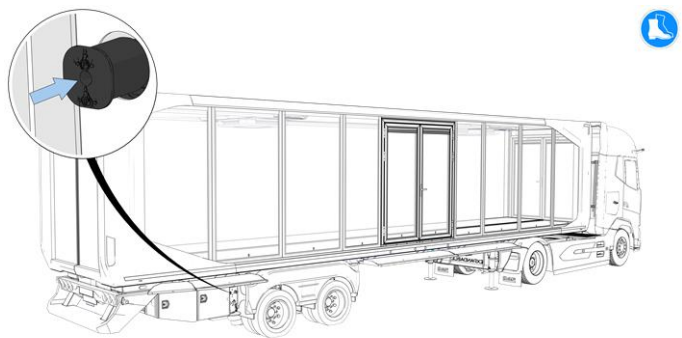

4. Push the black button to release the parking brake on the Expandable 44ft Trailer.



- Turn the lever clockwise to release the pressure in the bellows. Lower the rear of the Expandable 44ft Trailer as far as possible.

		Note the Expandable 44ft Trailer may tip backwards!!!
		Ensure that the rear of the Expandable 44ft Trailer does not touch the ground.

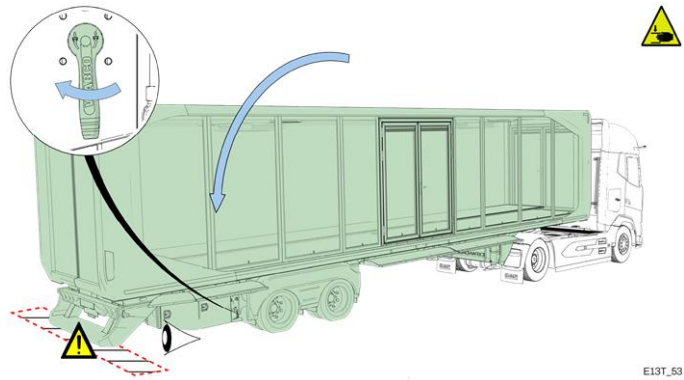

E13T_53

- Press the **2** and **4** buttons on the remote control simultaneously to extend the piston rods of the front lifting cylinders until they touch the ground.

		Use the supplied out-rigger plates.
---	---	--

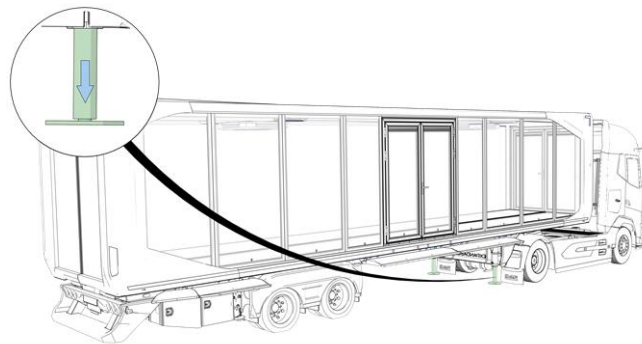

E13T_18

- Pull out the red button to engage the parking brake on the Expandable 44ft Trailer.
- Unlock the fifth wheel coupling.
- Disconnect the hoses and cables between the tractor unit and the Expandable 44ft Trailer.
- Drive the tractor unit out from underneath the Expandable 44ft Trailer.

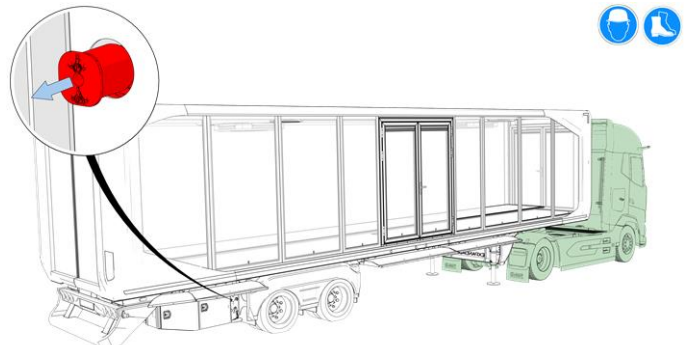

E13T_74

- Press keys **1** and **3** on the remote control to retract the piston rods of the front lift cylinders until the front of the Expandable 44ft Trailer reaches the lowest possible position.

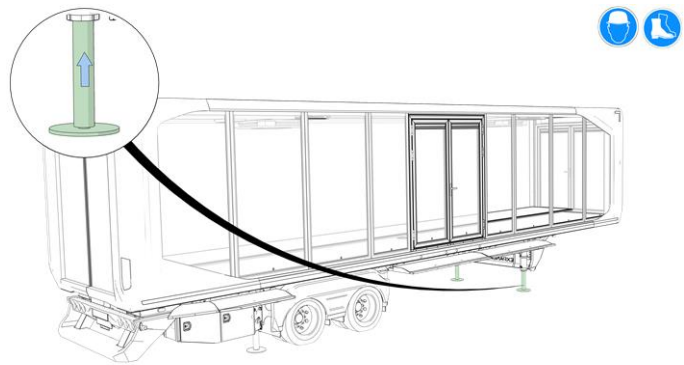

E13T_68

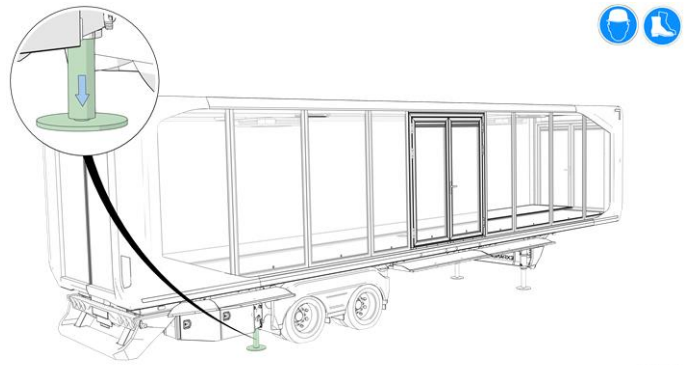

12. Press the **6** and **8** buttons on the remote control simultaneously to extend the piston rods of the rear lifting cylinders until they touch the ground.

		Use the supplied outrigger plates.
---	---	---



E13T_19

13. Press button **9** to automatically level the Expandable 44ft Trailer

		Place wheel chocks in front of and behind the wheels.
---	---	--

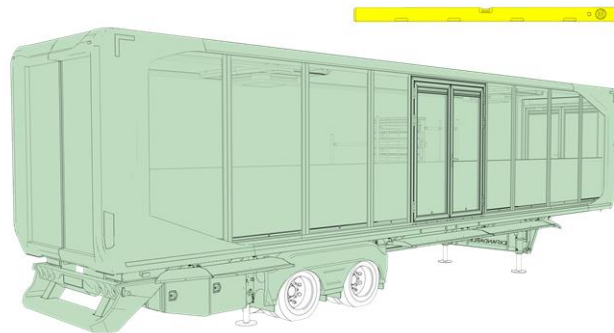

Acoustic signals

- During levelling: short beep signals
- Completed: 3 beep signals
- Unsuccessful: 3 beep signals + notification



E13T_20

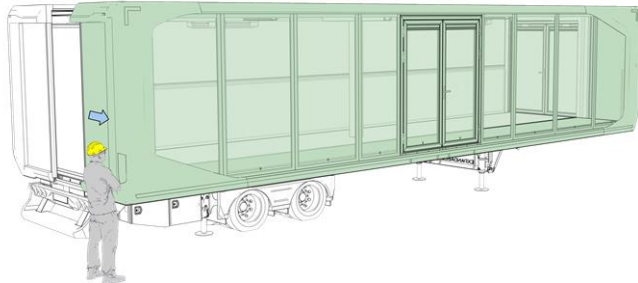

14. Press button **13** to extend the right slide-out.

		Stop immediately if any deformation occurs during extension. Identify and eliminate the cause of the deformation before continuing to extend the slide-out.
---	---	--



E13T_21

15. Press button **11** to extend the left slide-out.

		Stop immediately if any deformation occurs during extension. Identify and eliminate the cause of the deformation before continuing to extend the slide-out.
---	---	--



E13T_22

16. Tilt down both floorboards at the front.



17. Tilt down both floorboards at the back.

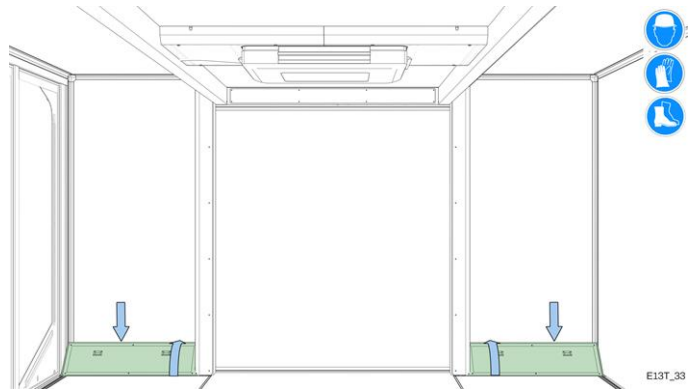

18. Turn the battery master switch to the "OFF" position.

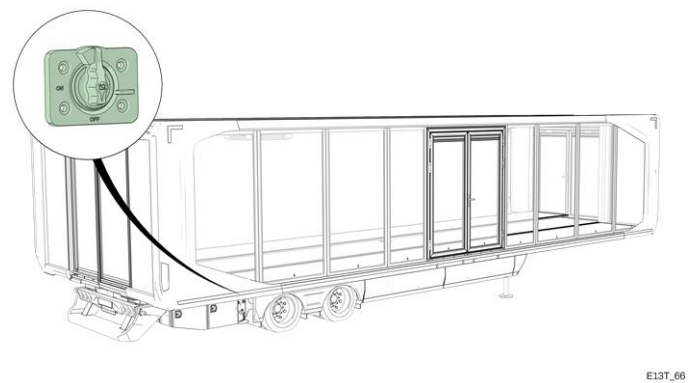

4. Commissioning

This chapter describes the operation of electrically operated accessories, such as electrically powered access doors, access to the roof terrace, and similar features.

4.1 Connecting Shore Power

Follow the procedure below to connect the shore power supply.

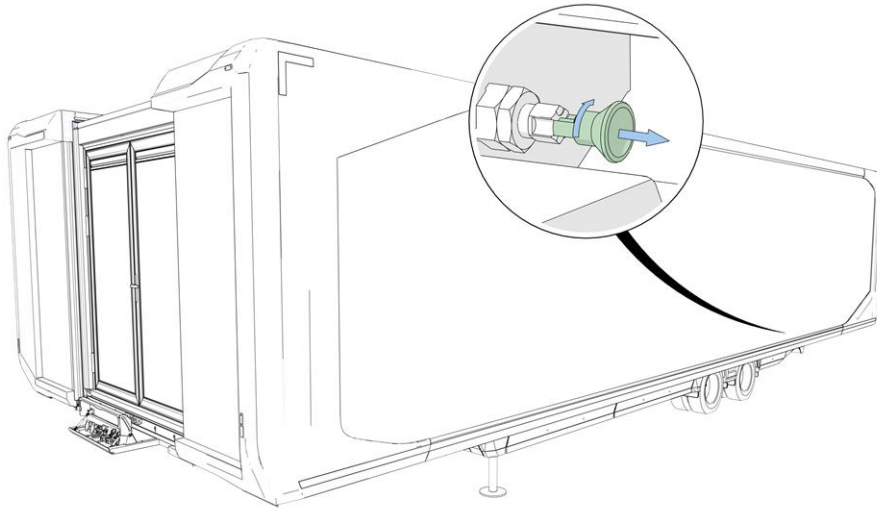

E13T_71

1. ⬆️ Unlock the crash protection on the left-hand rear side and tilt it upwards.

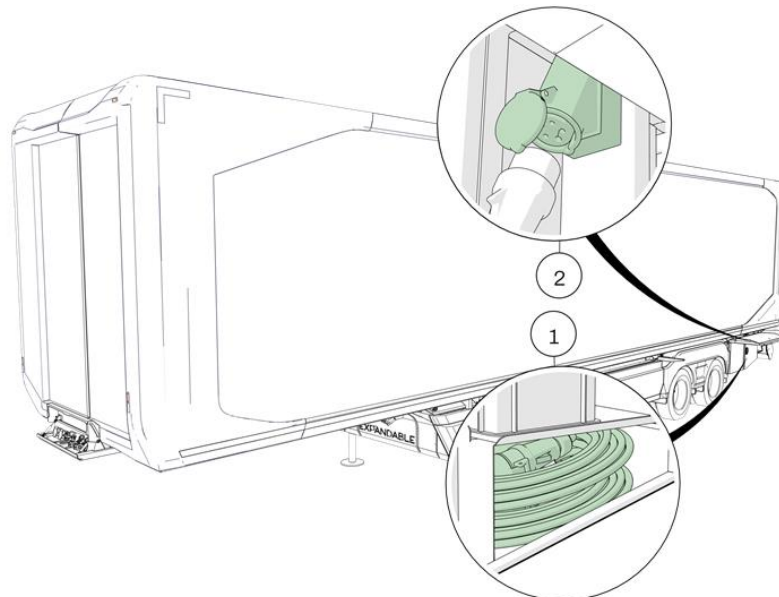

E13T_06

1. Extension cable

2. Shore power supply

2. ⬆️ Unlock and open the storage compartment door. The extension cables required for the shore power connection can be taken from the storage compartment.
3. Connect the extension cable to the shore power supply.

4.2 Power Shutdown

Expandable B.V. recommends that users switch off the power temporarily if the Expandable 44ft Trailer is left on site for an extended period. This recommendation applies solely to the Expandable 44ft Trailer. All hydraulic equipment can be switched off using the battery master switch. All other equipment is powered through the shore power connection. If external devices are connected to the Expandable 44ft Trailer—such as refrigerators or electronic equipment—it is the user’s responsibility to determine whether the power supply to these devices may be switched off.

Follow the procedure below.

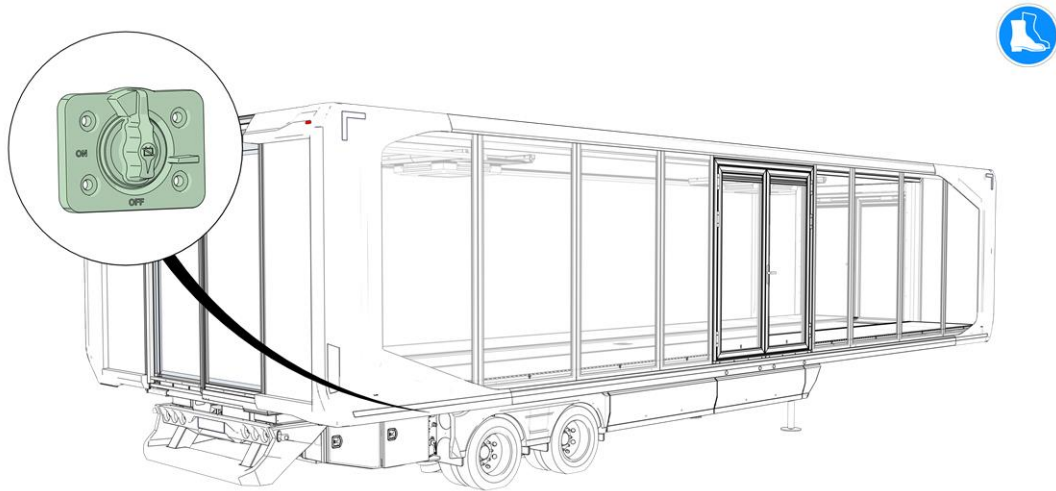

E13T_23

1. ↑ Turn the battery master switch to the “OFF” position to switch off the power.



Lock the battery master switch with a padlock to prevent unauthorised use.

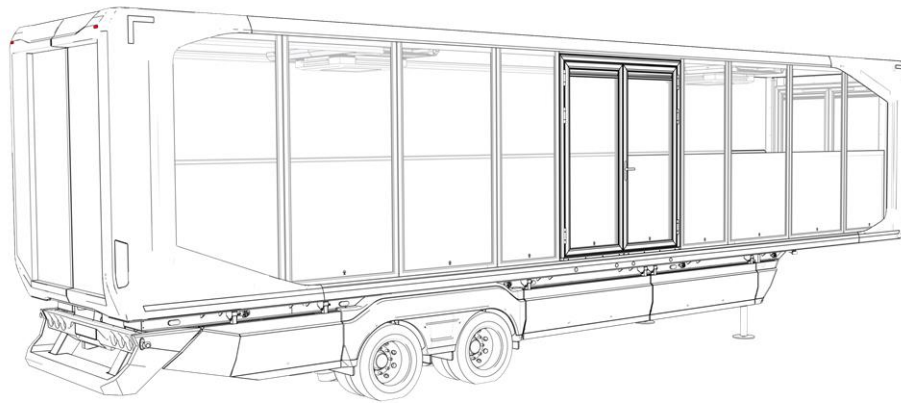

E13T_63

5. Preparing the Expandable 44ft Trailer for Transport

In this chapter, you will find information on making the Expandable 44ft Trailer ready for transport and coupling it.

5.1 Preparation for transport

Procedure

Follow the procedure below.

1. Turn the battery master switch to the "ON" position.

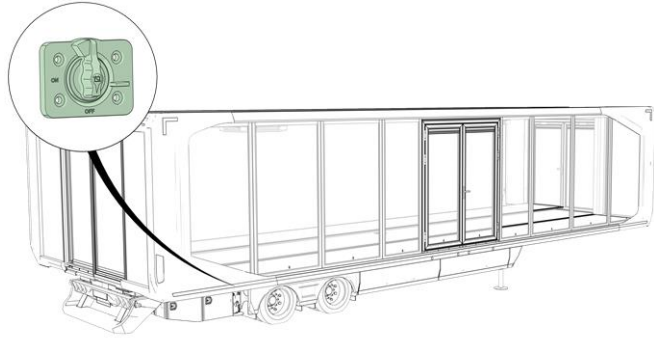

E13T_66

2. Remove both floorboards at the front.

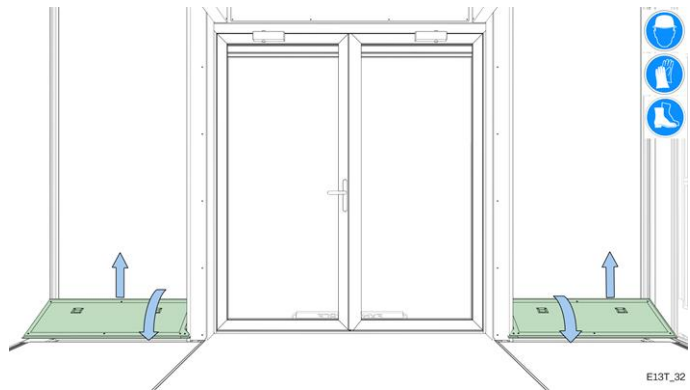

E13T_32

3. Remove both floorboards at the rear.

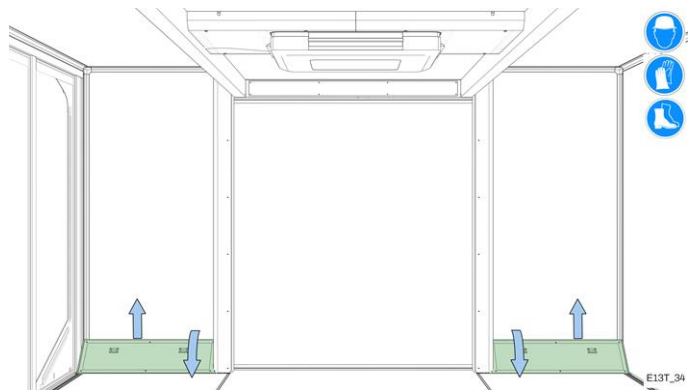

 Lock all doors and store the keys in the key safe.

 Remove all objects from the fold-down floors.



E13T_34

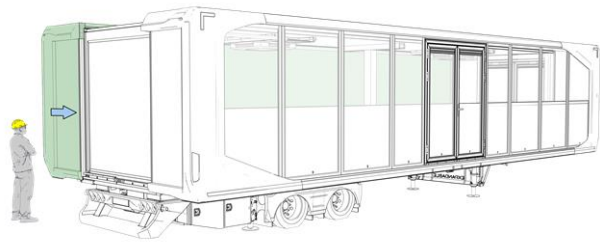

- Press button **12** to retract the left slide-out.

		<p><i>Stop immediately if any deformation occurs during extension. Identify and eliminate the cause of the deformation before continuing to extend the slide-out.</i></p>
---	---	---



E13T_24

- Press button **14** to retract the right slide-out.

		<p><i>Stop immediately if any deformation occurs during extension. Identify and eliminate the cause of the deformation before continuing to extend the slide-out.</i></p>
---	---	---



E13T_25

- Press buttons **2** and **4** to raise the front of the Expandable 44ft Trailer in order to couple it.

	<p><i>Ensure that the bumper does not touch the ground.</i></p>
---	---

- Press buttons **6** and **8** to slightly extend the piston rods of the rear lift cylinders so that the bumper remains clear of the ground. (See "Vacuum Collapse of the Air Bellows on page 46").

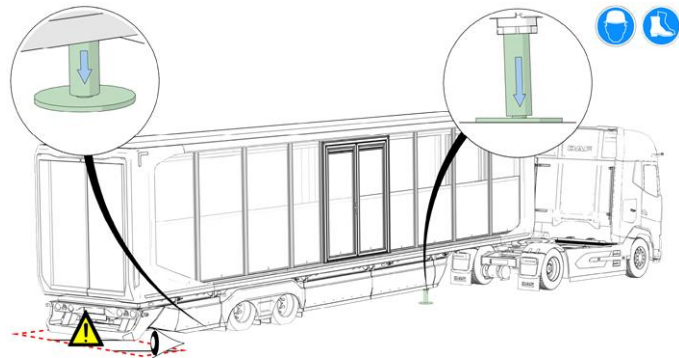

E13T_27

- Couple the tractor unit.
- Connect the cables and the air hoses.

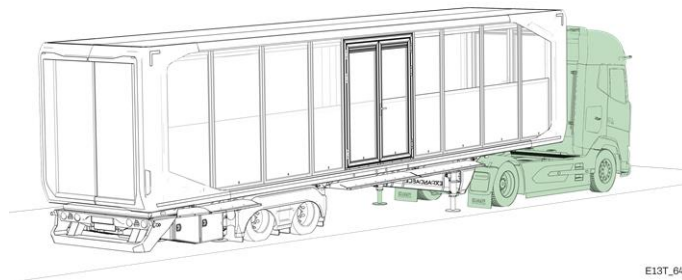

E13T_64

- Connect the red air hose. Turn the tap fully counterclockwise and hold it until the trailer no longer rises. (During this process, the air bellows can be heard expanding.)

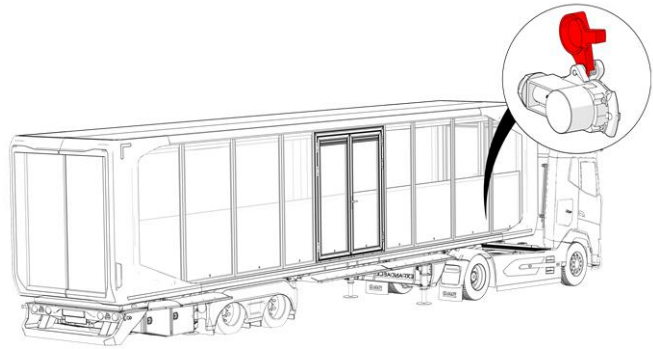

E13T_39

- Press the red button in.

		Remove the wheel chocks.
--	--	---------------------------------

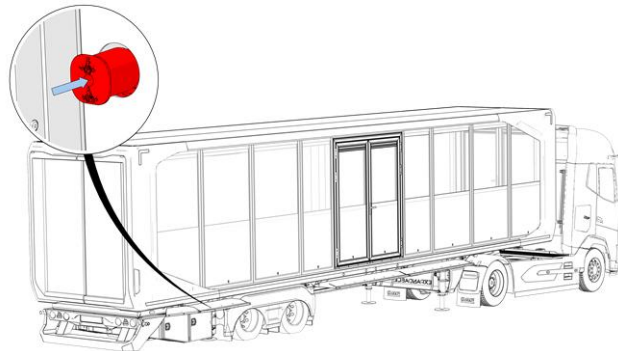

E13T_69

- Press buttons 1 and 3 to fully retract the piston rods of the front lift cylinders.

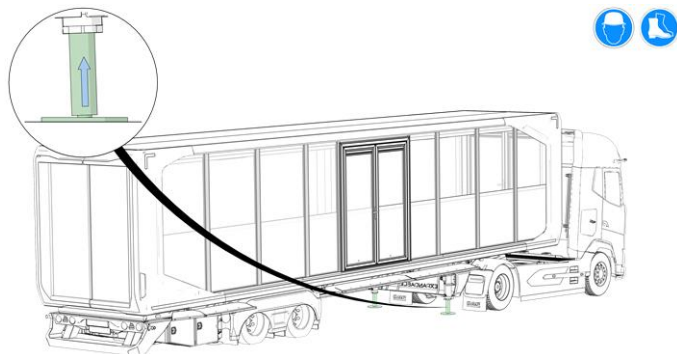

E13T_57

- Turn the tap fully counterclockwise and hold it until the trailer no longer rises. (During this process, the air bellows can be heard expanding.)

		Do not use the rear lift cylinders to lift the Expandable 44ft Trailer at the rear.
--	--	--

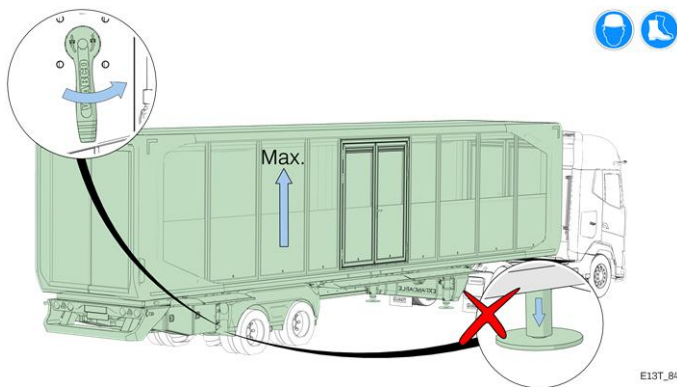

E13T_84

14. Turn the tap to the middle position so that the trailer returns to driving height.

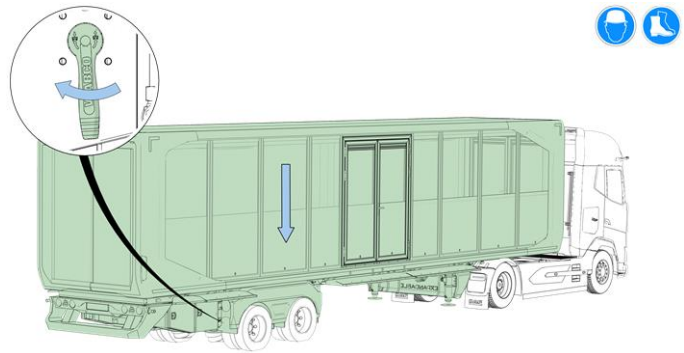

E13T_75

15. Press buttons 5 and 7 to fully retract the piston rods of the rear lift cylinders.

		<i>Store the outrigger plates.</i>
--	--	------------------------------------

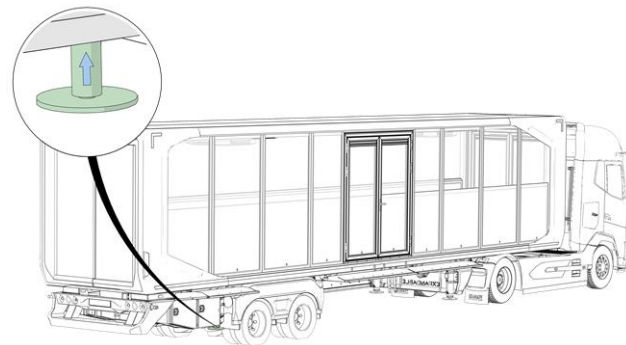

E13T_65

16. Turn the battery master switch to the "OFF" position.

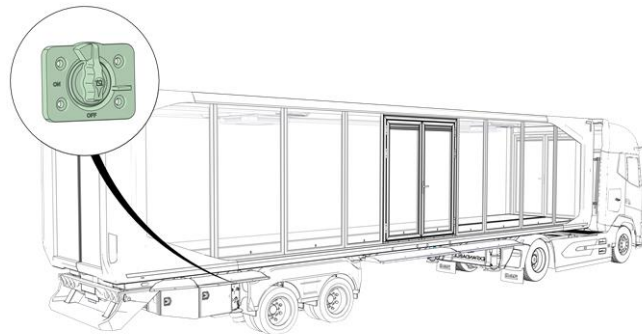

E13T_15

17. Tilt the crash guards down on both sides.

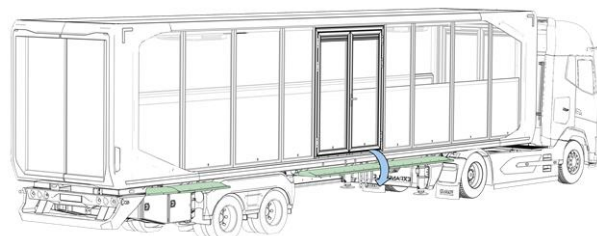

E13T_30

18. Connect the yellow air hose.

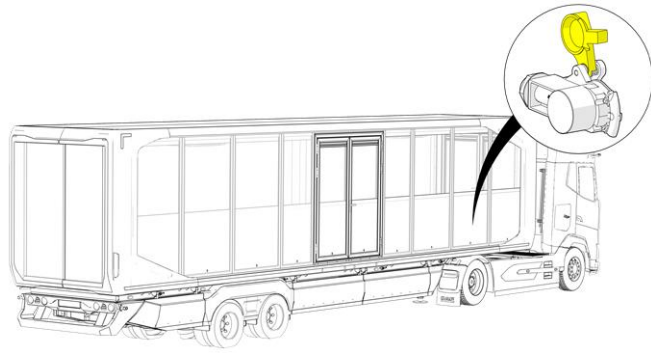

E13T_76

5.2 Vacuum Collapse of the Air Bellows

As soon as you fully deflate the air bellows and then raise the rear lift cylinders, the air bellows are pulled into a vacuum by the weight of the suspension, because no air can enter the bellows. (see "Fig. 5-1").

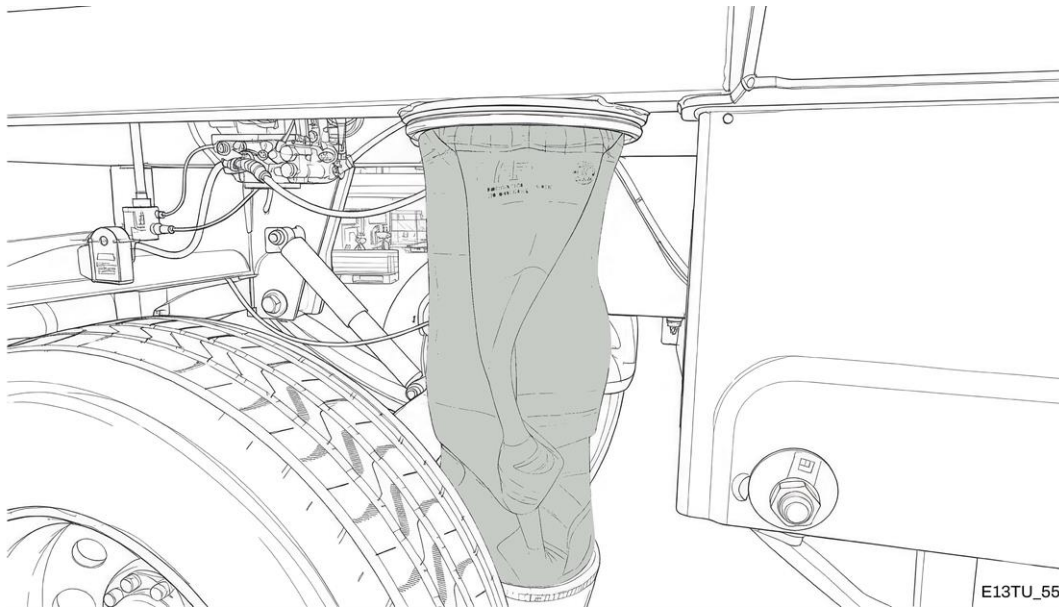
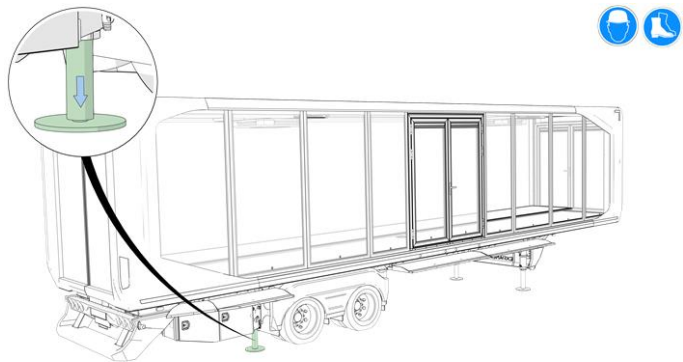

Fig. 5-1

If the Expandable 44ft Trailer is then lowered again, the bellows will become jammed between the upper and lower mounting points and possibly other parts of the suspension. If air is then pumped into the air bellows, they can be seriously damaged.

Follow the procedure below as soon as such a situation occurs.

1. Press buttons **6** and **8** on the remote control to lift the Expandable 44ft Trailer at the rear to driving height.



2. Fill the air tanks by coupling a tractor unit and connecting the red air hose.

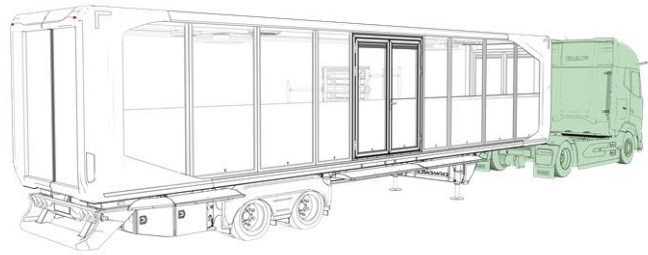

E13T_56

3. Turn the lever counter clockwise to pump some air into the bellows until you hear a popping sound from the bellows. This sound indicates that the bellows are in the correct position.

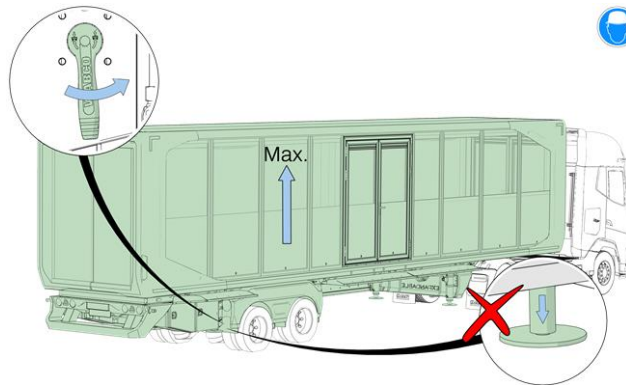

E13T_84

4. Then turn the lever to the middle position. The Expandable 44ft Trailer will return to its normal driving height.

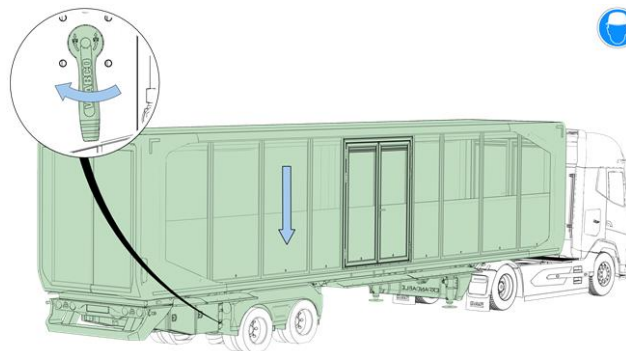

E13T_75

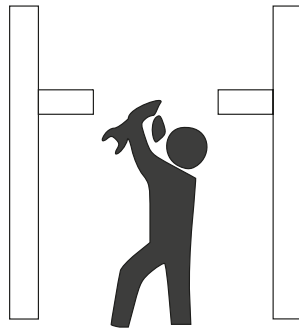

6. Periodic Maintenance

In this chapter, you will find information about the maintenance you need to perform on your Expandable 44ft Trailer. You will also find information about ordering parts.

6.1 Maintenance Schedule

In the table below, the components that require periodic maintenance are listed.

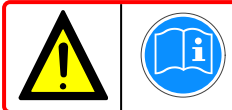

Expandable B.V. advises adhering to the maintenance intervals indicated in the table and using only products with the specified specifications. Order your required products from Expandable B.V. +31 (0)85 890 21 88 in a timely manner.

Check	Ref. Image	Work	Daily / Before use	Responsible Party
Sliding sleeves	Click	Check for pollution / remove	x	Driver / Operator
Non-retractable Roof	Click	Check for pollution / remove	x	Driver / Operator
Oil leakage / Hydraulic system	Click	Check / Report	x	Driver / Operator
Door Locks		Check / Report	x	Driver / Operator
Battery Voltage		Check / Report	x	Driver / Operator
Tire pressure 850 kPa (Cold)	Click	Check / Report	x	Driver / Operator
Rim and Tyre Damage		Check / Report	x	Driver / Operator
Exterior Trailer Lighting	Click	Check / Report	x	Driver / Operator
Brakes and Height Control		Check / Report	x	Driver / Operator
Number Plate and Reflectors		Check / Clean	x	Driver / Operator
EBS Fault Messages		Check / Report	x	Driver / Operator
Fifth Wheel and Kingpin Lubrication		Check / Report	x	Driver / Operator
Expandable 44ft Trailer Damage		Check / Report	x	Driver / Operator
Height Control Operation (Driving Position)		Check / Report	x	Driver / Operator
Underrun Protection Locking system	Click	Check / Report	x	Driver / Operator
Service			Interval	
Expandable Service 1			2000 Km/ 2 Weeks	Service Workshop
Expandable Service 2			30.000 Km/ Every 3 Months	Service Workshop
Expandable Service 3			60.000 Km / Every 60 Months	Service Workshop

Check	Ref. Image	Work	Daily / Before use	Responsible Party
Expandable Service 4			120.000 Km / Every 12 Months	Service Workshop

Table 6-1 Maintenance Schedule

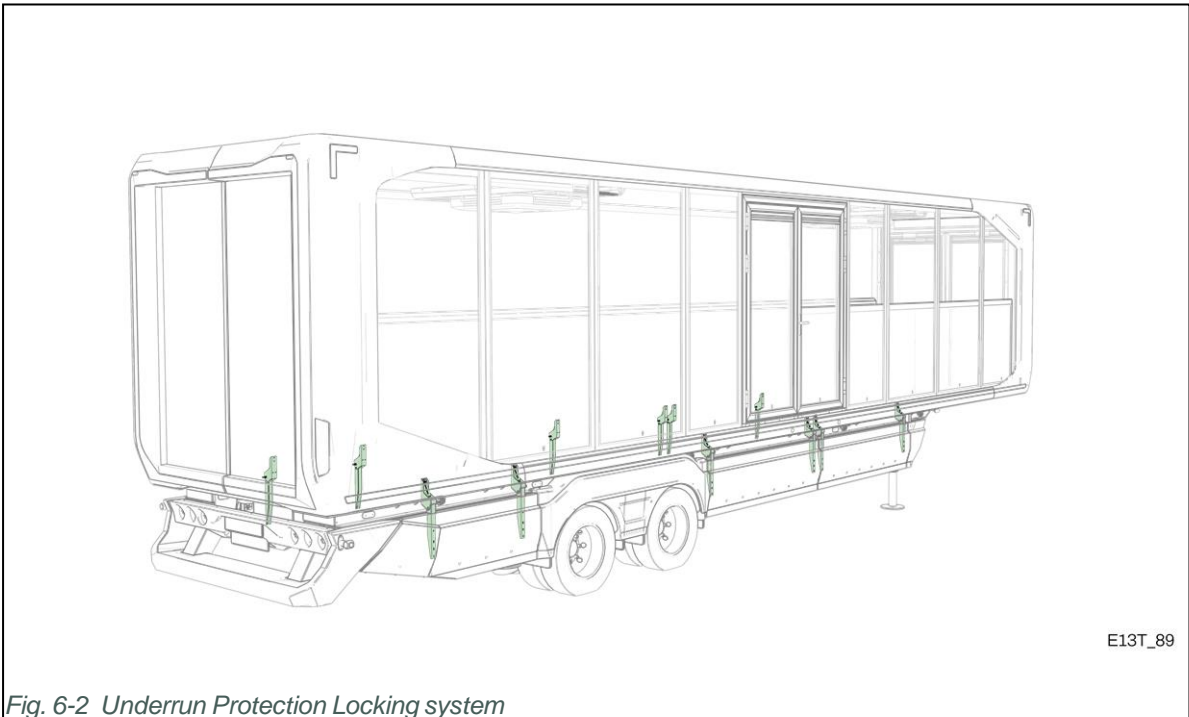
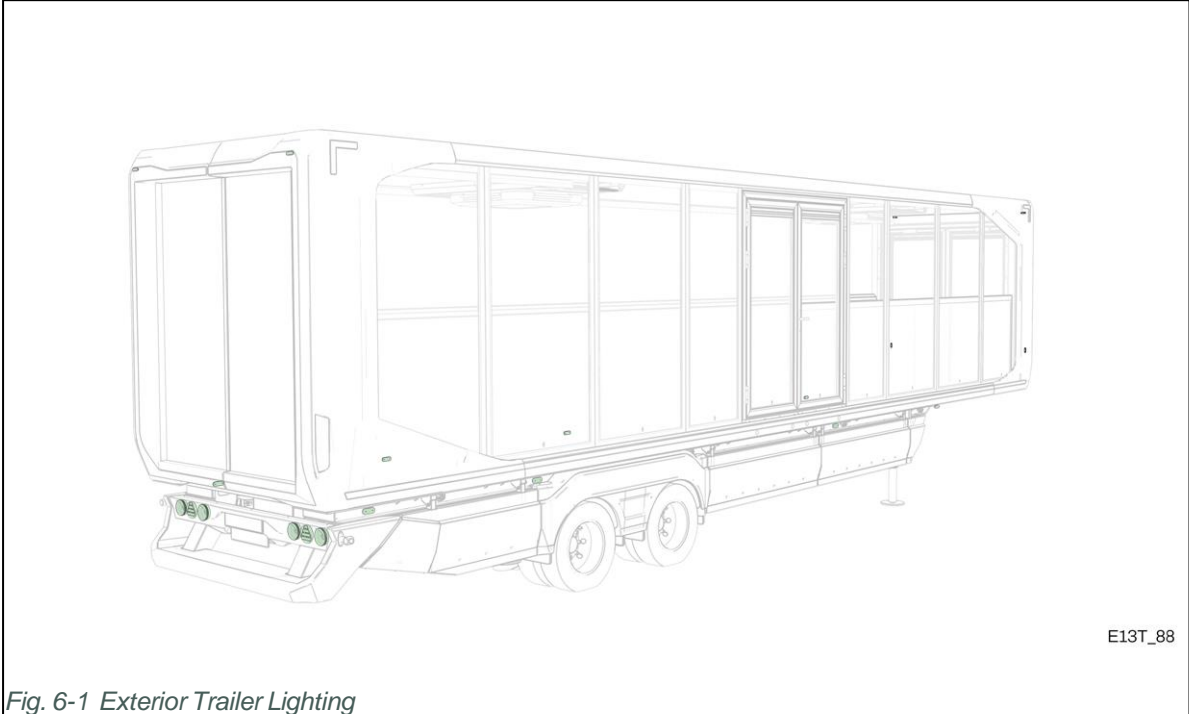

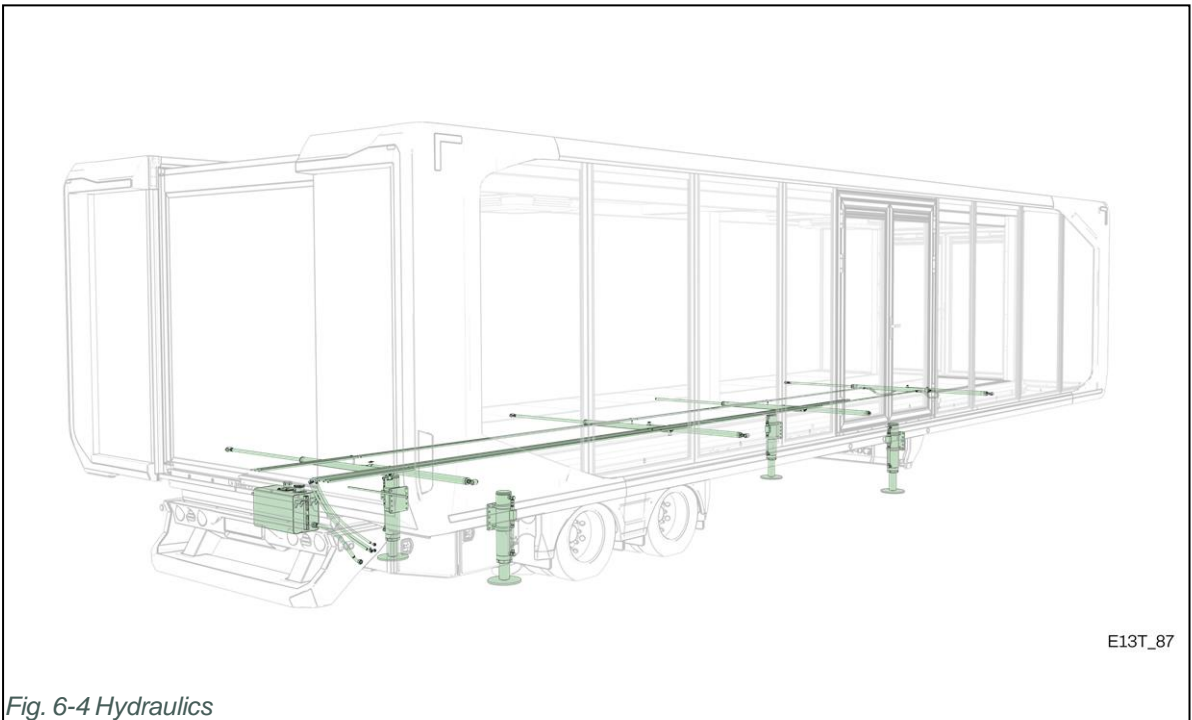
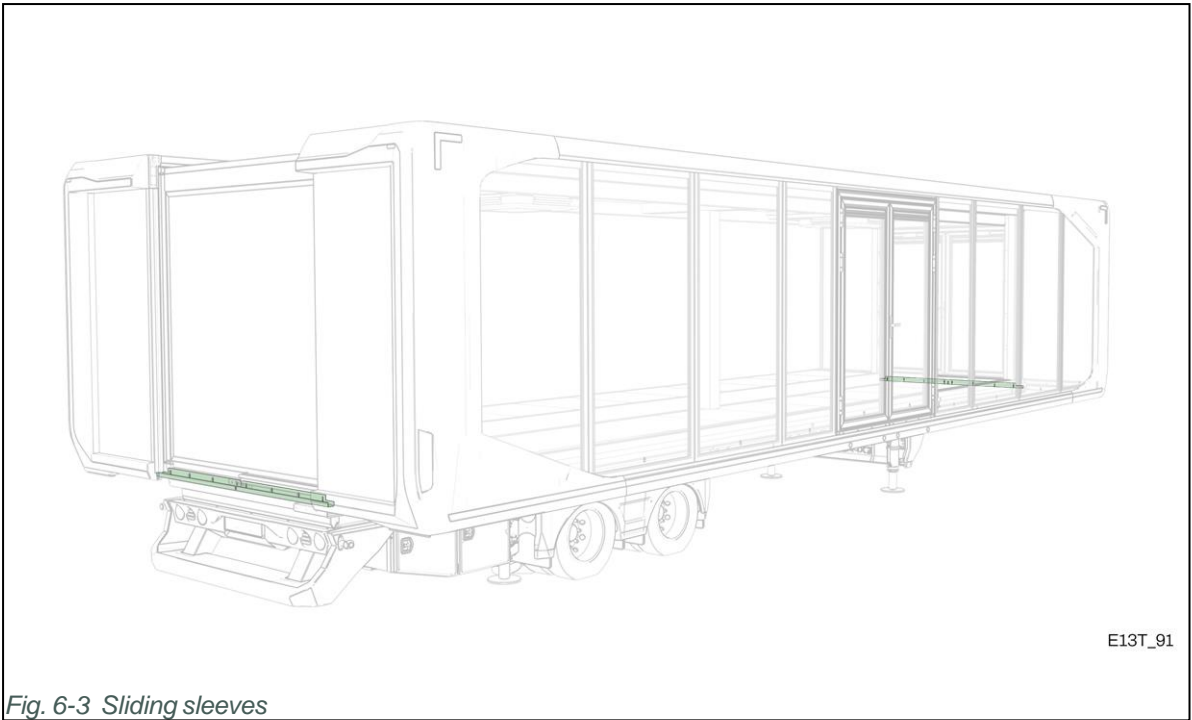

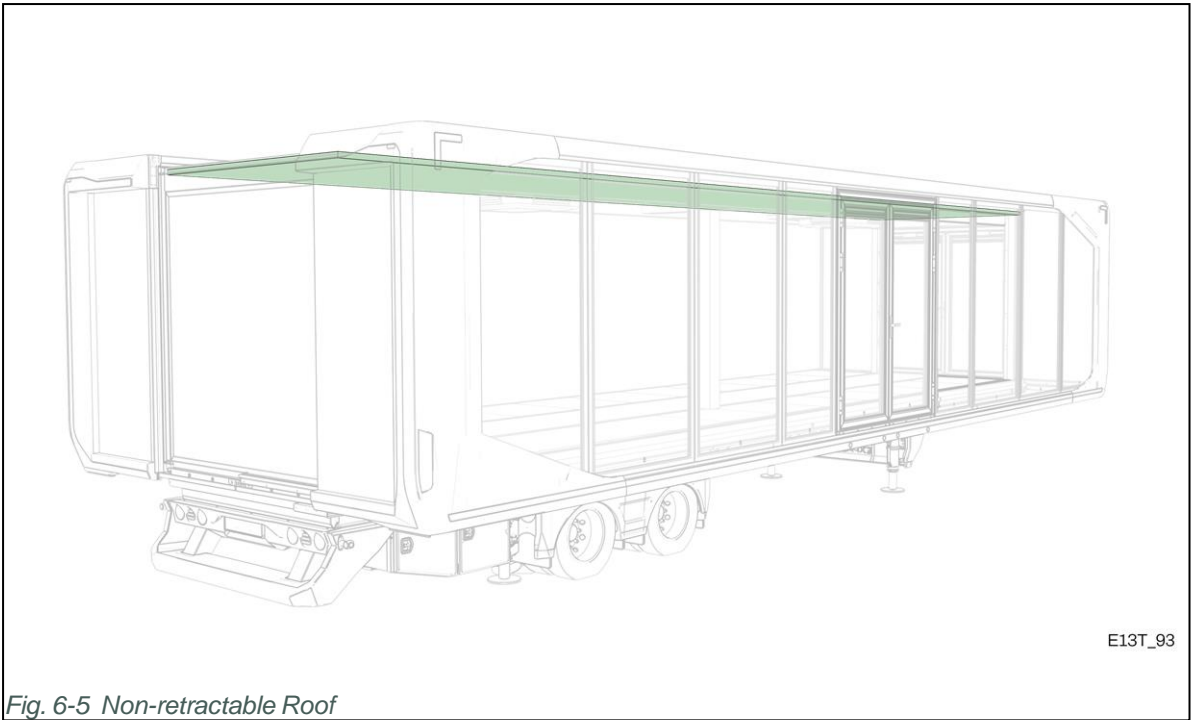

6.2 Oil level

For the hydraulic system to operate correctly, it is essential that the oil level is always at the correct level. To check the oil level properly, the following conditions must be met:

- *Couple the Expandable 44ft Trailer to the tractor unit.*
- *Ensure that the vehicle combination is level.*
- *Ensure that the piston rods of the lift cylinders are retracted. (See "Remote control Expandable 44ft Trailer on page 1").*
- *Ensure that the slide-outs are fully retracted.*

Procedure

Follow the procedure given below.

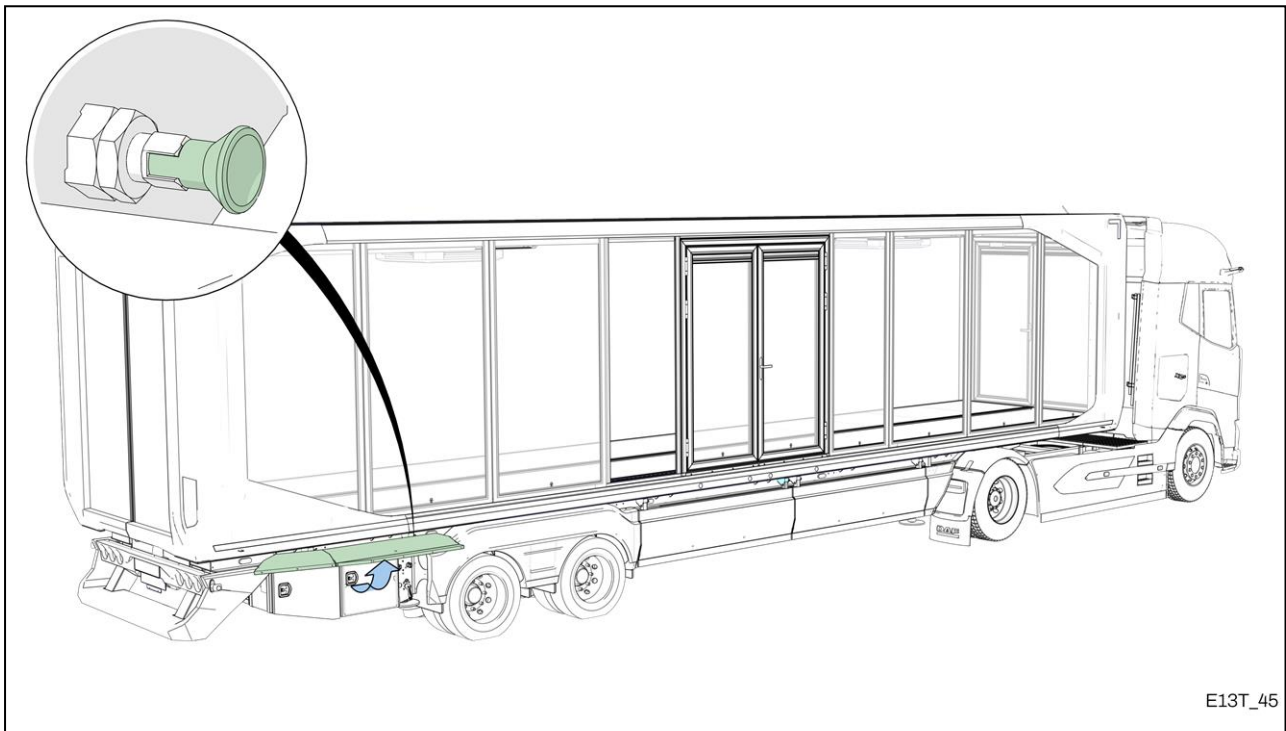

1. ↑ Tilt the rear right-hand side crash protection upwards.

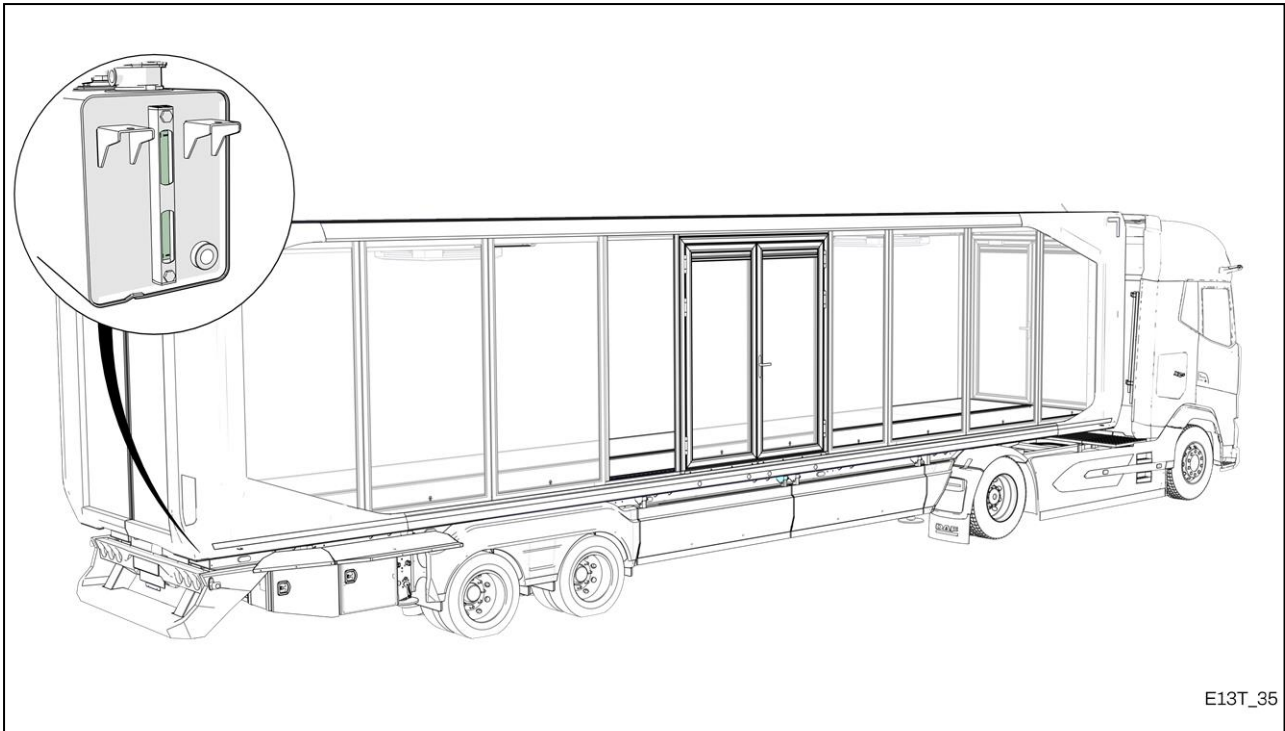

2. ↑ Check through the sight glass that the hydraulic oil level reaches the “MAX” indication. Top up the hydraulic oil if the level is below “MAX”.

6.2.1 Refilling Oil

As soon as the hydraulic oil level falls below the “MAX” mark, the oil must be topped up.



Hydraulic oil can only be topped up when the slide-outs are extended.

Procedure

Follow the procedure given below.

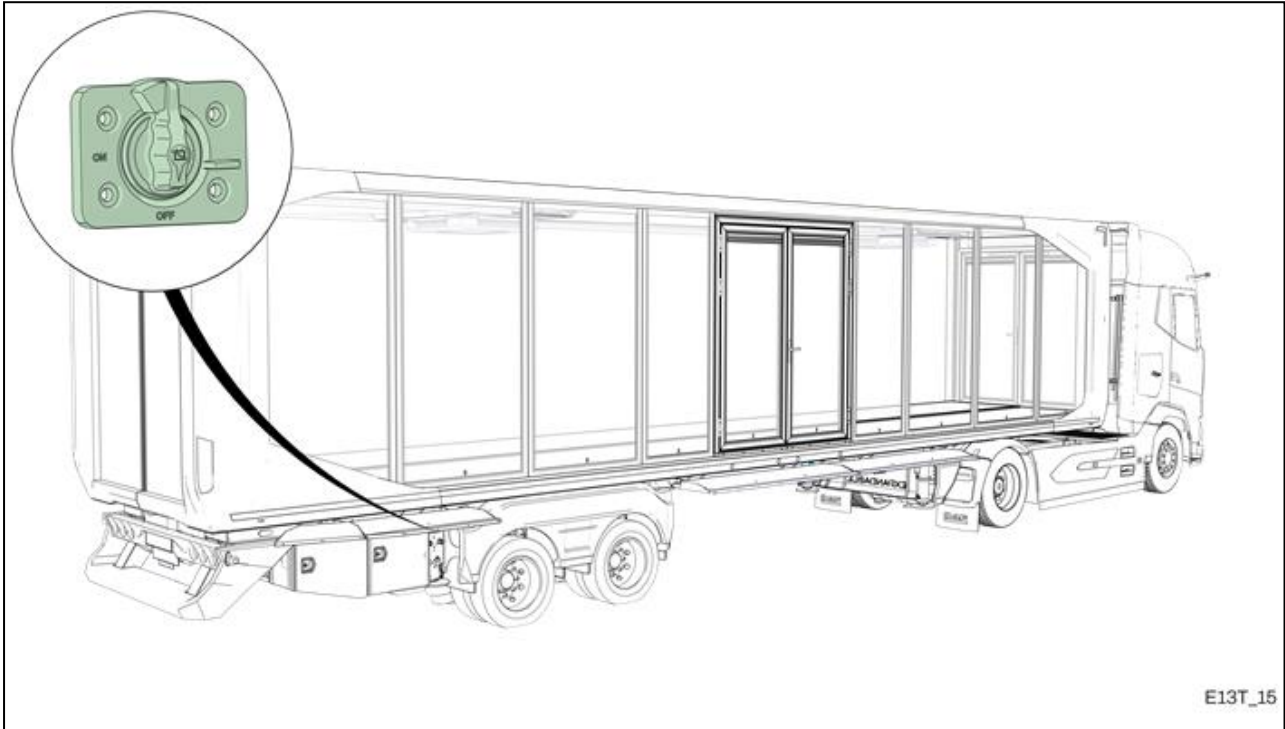

1. ↑ Set the battery master switch to the “ON” position.

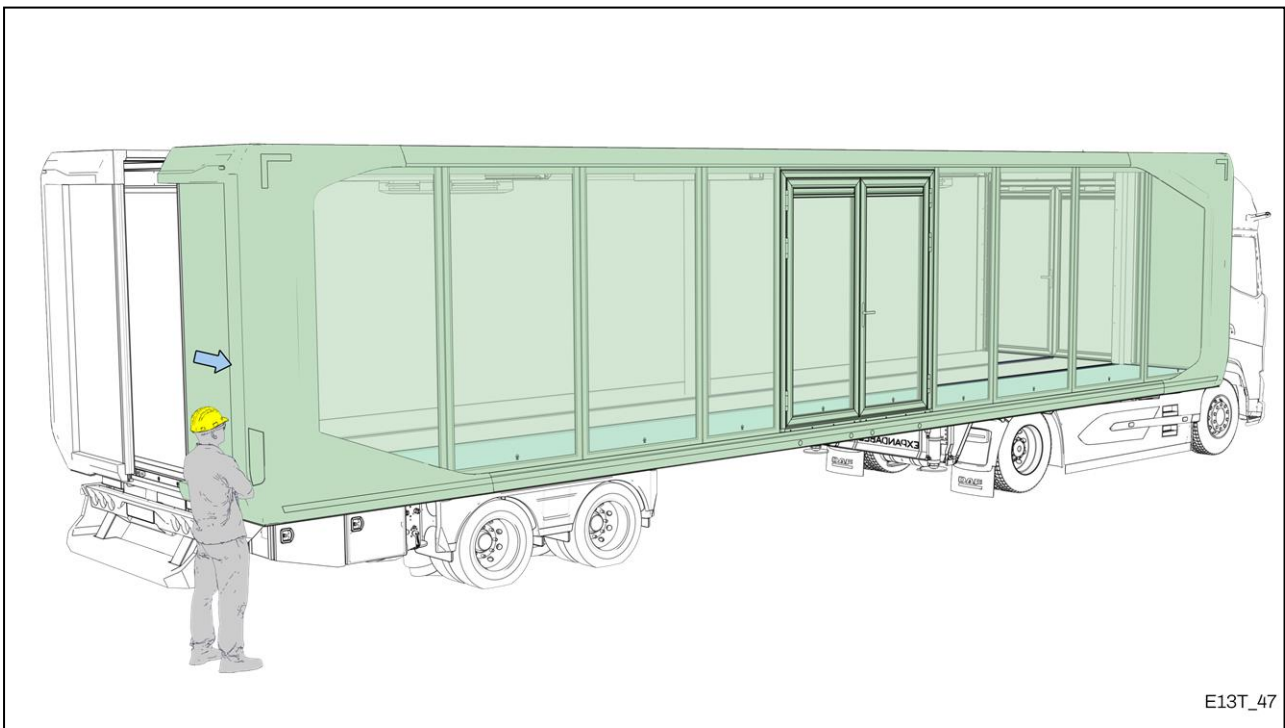

2. ↑Extend the right slide-out. (See "Extend right slide-out on page 1").

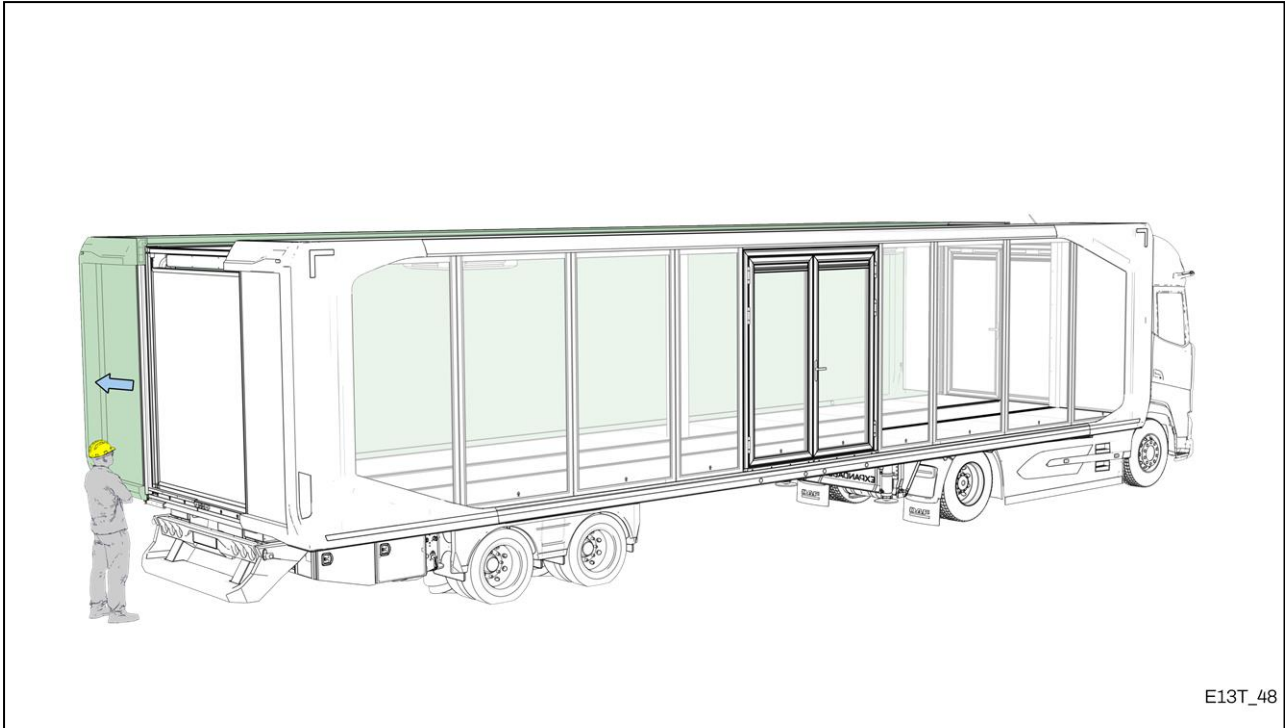

E13T_48

3. ↑Extend the left slide-out (See "Extend Left slide-out on page 1").



Stop immediately if any deformation occurs during extension. Identify and eliminate the cause of the deformation before continuing to extend the slide-out.

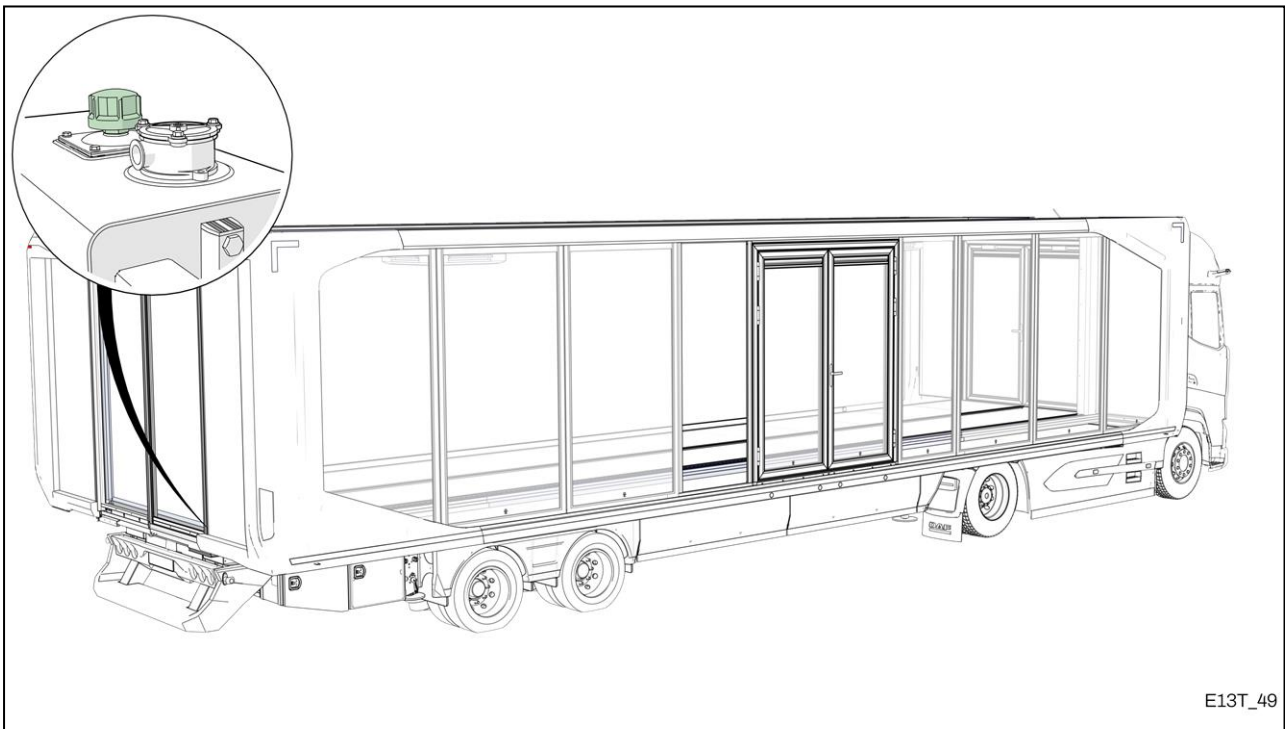

E13T_49

4. ↑Unscrew the cap on top of the tank and top up with hydraulic oil.
5. Tighten the cap.
6. Retract both slide-outs.
7. Set the battery master switch to the "OFF" position.

8. Tilt the crash protection downwards.
9. Disconnect the tractor unit if necessary.



To prevent damage to the hydraulic system and potential leaks, Expandable B.V. recommends making an appointment with the service workshop as soon as the hydraulic oil level rises above the "MAX" mark.

7. Safety & Environment

The following sections contain information on the safe use of the Expandable 44ft Trailer. They also describe how to proceed when the Expandable 44ft Trailer has reached the end of its service life.

7.1 Environment

ENVIRONMENTAL NOTICE

Once the Expandable 44ft Trailer has reached the end of its service life for any reason, it must be dismantled and disposed of in accordance with applicable local and/or national regulations.

Always contact your local or national government service, waste management authority, or the supplier from whom you purchased the Expandable 44ft Trailer for information on approved recycling and disposal facilities.

Proper disposal helps prevent environmental damage and ensures that recyclable materials are processed responsibly.

7.2 Safety During Use

 The use of a Expandable 44ft Trailer may involve risks.

Always consult the relevant regulations (e.g., traffic laws, company procedures, safety and health regulations) applicable in the country where the Expandable 44ft Trailer is being used.

General Instructions for Using a Expandable 44ft Trailer:

- *Never set up the Expandable 44ft Trailer on terrain that exceeds the allowable slope limits.*
- *Never use or position a Expandable 44ft Trailer on public roads unless it has been confirmed that the entire Expandable 44ft Trailer complies with national road traffic legislation.*
- *Read the user manual **BEFORE** coupling and/or using a Expandable 44ft Trailer.*
- *Perform the daily inspection **BEFORE** coupling and/or using a Expandable 44ft Trailer.*
- *During transportation the driver of the tractor unit is responsible for safe travel and operation of the Expandable 44ft Trailer.*
- *Only manoeuvre the Expandable 44ft Trailer when **NO** people or animals are in the immediate vicinity of the moving parts.*

The nature of potential hazards and limitations during use are represented by the pictograms shown below.



8. General Information

In the following paragraphs, you will find general information regarding this User manual and the product manufactured by Expandable B.V..

8.1 Cleaning

Use a mild detergent and rinse it off with water from a hose at low pressure. Expandable B.V. strongly recommends **NOT** cleaning the Expandable 44ft Trailer with aggressive or corrosive detergents. Using a pressure washer or cleaning the Expandable 44ft Trailer in a car wash is strongly discouraged. This is to prevent the film on wrapped parts of the Expandable 44ft Trailer from loosening.

8.2 Vehicle Registration and Delivery

 When an Expandable 44ft Trailer is handed over to the customer, all accompanying documentation related to the Expandable 44ft Trailer must be provided to the customer. Proper registration and documentation ensure legal compliance, safe operation, and traceability throughout the Expandable 44ft Trailer's service life.

Documentation That Must Be Provided at Delivery

The customer must receive the following documents upon delivery:

- *Certificate of Conformity (CoC) or EC/UK type approval documents*
- *User Manual for the trailer*
- *Maintenance and Inspection Logbook*
- *Hydraulic System Documentation, including schematics (if applicable)*
- *Electrical System Documentation*
- *TPMS Documentation (including certificates, sensor IDs, and instructions)*
- *Warranty Documentation*
- *Parts List and Ordering Information*
- *Delivery Checklist, signed by both the dealer and the customer Registration or Licensing Documents, if applicable in the destination country*

Customer Responsibilities at Delivery

The customer is responsible for:

- *Ensuring that the Expandable 44ft Trailer is registered with the appropriate national authority (DVLA, RDW, TÜV, or equivalent).*
- *Verifying that the trailer's VIN number (Vehicle Identification Number) matches the documentation.*
- *Confirming that all safety systems (lighting, air systems, TPMS, brakes) are operational.*
- *Keeping all documentation in a secure place for future inspections or audits.*

Dealer or Supplier Responsibilities

Expandable, the dealer, or the authorised distributor must:

- *Provide a fully functional and tested trailer at delivery.*
- *Ensure that all required documentation is complete and up to date.*
- *Perform a final inspection and demonstrate basic operation to the customer. Explain key safety systems, including hydraulic operation, TPMS, and emergency procedures.*
- *Provide contact details for after-sales support and service.*

Registration Requirements

Trailer registration and licensing requirements vary by country. The customer must consult local authority guidelines. Typical items that may be required:

- *VIN inspection*
- *Weight and dimension specifications*
- *Brake system compatibility*
- *Lighting and reflector compliance*
- *TPMS compliance (if applicable according to local law)*

Expandable B.V. recommends verifying national regulations before first use to avoid delays or fines.

- 

The vehicle must not be used until it has been confirmed that the tractor unit to which the Expandable 44ft Trailer is coupled complies with national road traffic laws.
- 

National road traffic laws are specific to each country. Contact the national inspection authority in the respective country for the required information.

Subject	Action
Safety Warning Label	Check that the warning stickers are placed in such a way that they are clearly visible to the users.
User manual	The user manual of the Expandable 44ft Trailer is handed over to the customer upon delivery. Inform the customer that the user manual should always be kept with the Expandable 44ft Trailer.
Warranty	Warranty for products from Expandable B.V. can be found in the delivery terms General-terms-and-conditions .

Table 8-1 Delivery Documents

8.3 Terrain Conditions

Your Expandable 44ft Trailer should preferably be prepared for use and transport on terrain that is level both longitudinally and laterally. A certain amount of slope is permitted, provided that the slope angles do not exceed the maximum allowable values shown in the table (see "Table 8-2"). The maximum allowable slope angles, both longitudinally and laterally, are shown below:

	Slope Angle
Longitudinal	2°
Lateral	3°

Table 8-2 Slope Angles

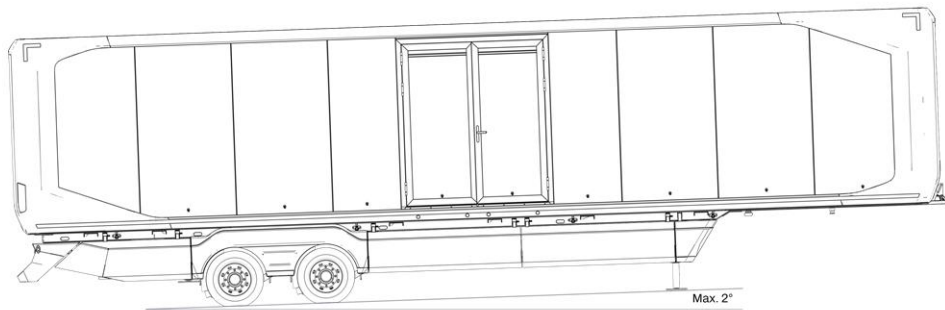

E13T_36

Maximum longitudinal slope angle

Fig. 8-1

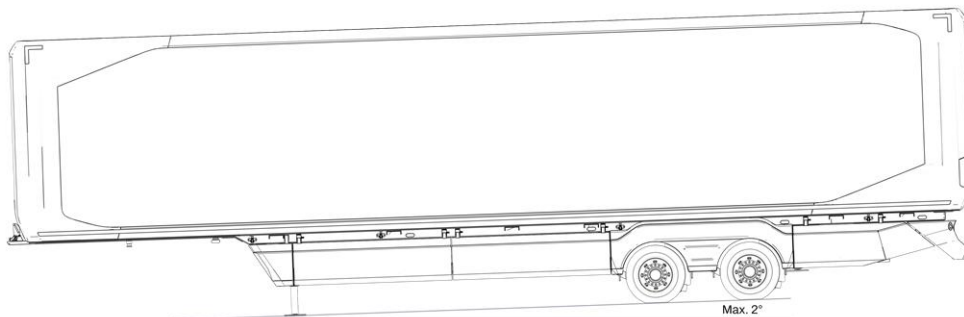

E13T_37

Maximum longitudinal slope angle

Fig. 8-2

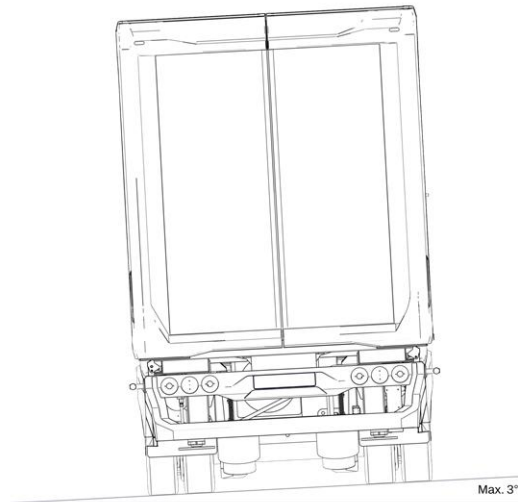

E13T_38

Maximum lateral slope angle

Fig. 8-3

Always determine, before preparing the Expandable 44ft Trailer for use, whether the terrain is sufficiently load-bearing to support the weight of the Expandable 44ft Trailer including its interior. Use the supplied outrigger plates under the lifting cylinders.

8.4 Checking and Recharging Battery Voltage

The batteries are normally recharged via the built-in trickle charger as soon as the shore power is connected. The battery voltage must be checked at the batteries located in the storage compartment on the left-hand rear side. The battery voltage must be 24 V (the batteries are connected in series), with 12 V per battery. Checking the battery voltage via the NATO socket is not possible. If the battery voltage is too low for any reason, the batteries can be recharged via the tractor unit.

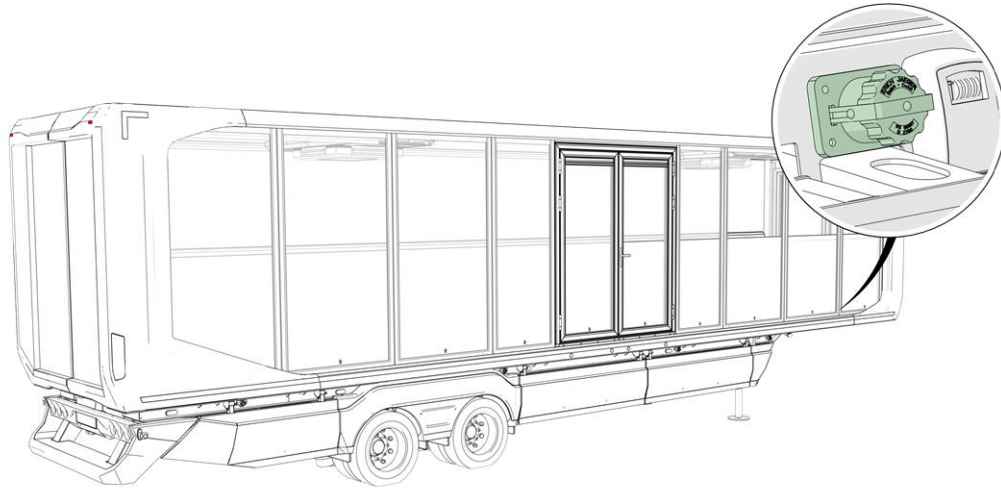

E13T_51

Fig. 8-4

8.5 VIN Plate and ALR Plate

On the chassis of the Expandable 44ft Trailer, the VIN plate shown below is affixed. This sticker provides information on:

- *the maximum load per axle*
- *the total weight*
- *the VIN number*
- *the type of trailer*
- *the production date*

MANUFACTURED BY: EXPANDABLE B.V.		DATE OF MFG:	
GVWR:	kg (LB)		
GAWR: (EACH AXLE)	(WITH TIRES)	(RIMS AT)	(COLD)
<hr/>			
7711 kg (17000 LB)			
THIS VEHICLE CONFORMS TO ALL APPLICABLE U.S. FEDERAL MOTOR VEHICLE SAFETY STANDARDS IN EFFECT ON THE DATE OF MANUFACTURE SHOWN ABOVE			
V.I.N.:	TYPE :	TRAILER	

TIRE AND LOAD INFORMATION RENSEIGNEMENTS SUR LES PNEUS ET LE CHARGEMENT		SEE OWNER'S MANUAL FOR ADDITIONAL INFORMATION VOIR LE MANUEL D'USAGER POUR LE PLUS DE RENSEIGNEMENTS	
The weight of cargo should never exceed 10205 KG (22500 LB)			
TIRE	SIZE		COLD TIRE PRESSURE
FRONT	NONE		
INNER	NONE		
REAR		KPA (PSI)	
SPARE	NONE		

Fig. 8-5

	<p><i>The type sticker must always be legible. Replace the sticker as soon as it becomes illegible. In such a case, contact Expandable B.V. ☎+31 (0)85 890 21 88 to order a new sticker. The sticker must not be replaced by a sticker produced by third parties without written permission from . The type sticker must always be legible.</i></p>
---	---

The ALR plate and type sticker are affixed to the inside of the right chassis beam.

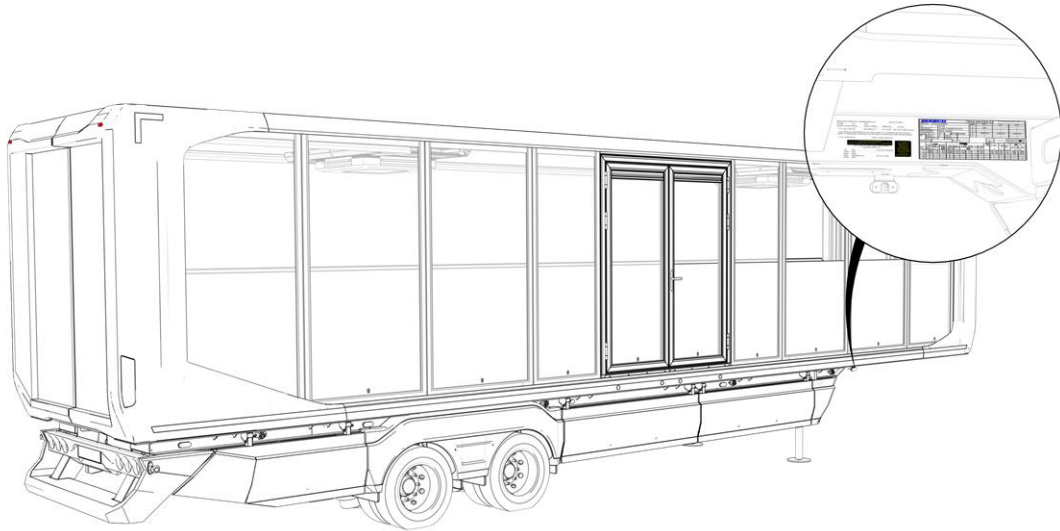

E13T_67

Fig. 8-6

  No changes may be made to the ALR plate and the type sticker. Contact Expandable B.V. if the sticker or the ALR plate has become illegible.

8.6 Expandable 44ft Trailer Specifications

In the table below, the specifications for the Expandable 44ft Trailer are listed.

	44 ft
Maximum weight	27000 Kg (59524 lbs)
Load capacity	12000 Kg (26455 lbs)
Axle load	9000 Kg (19841 lbs)
Rim size	19.5"
Tyre size	235/70/R19.5
Tyre pressure (cold)	850 KPA
External length	13.6 m (approx. 42ft 8")
External width	2.55 m (approx. 6ft 7")
External height	4.00 m (approx. 13ft 1")
Internal surface area in transport position	26 m ² (approx. 279.86 sqft)
Internal surface area in usage position	61 m ² (approx. 656.59 sqft)
Internal volume in transport position	65 m ³ (approx. 699.65 sqft)
Internal volume in usage position	152 m ³ (approx. 5,367.8 ft ³)
Maximum number of people on the roof when used as a roof terrace	17 (average 84 kg (185 lbs) per person)
Maximum load on middle roof	2000 Kg (4400 lbs)

Table 8-3 Expandable 44ft Trailer specifications

8.7 Oil Specifications

Bosch Rexroth	RE 90220 notes	Eaton Brochure	03-410-2010
DIN	51517-2 CL	ISO	11158 HM
DIN	51524-2 HLP	MAG IAS	P-68, P-69, P-70
Density	HF-0, HF-1, HF-2	Swedish Standard	SS 115434 AM

Table 8-4 Oil Specifications

8.7.1 Oil Properties

	Method	Unit	Properties
ISO viscosity grade			32
Density, 15°C	D 4052	g/ml	0.87
Kinematic viscosity 40°C	D 445	mm ² /s	32.2
Kinematic viscosity 100°C	D 445	mm ² /s	5.6
Viscosity index	D 2270		111
Acid number TAN	D 974	mg KOH/g	0.3
Pour point	D 97	°C	-30
Flash point, COC	D 92	°C	208
Emulsion, distilled water, 54.4°C	D 1401		40-40-0(10)
Foam, 5 min blowing, seq. 1/2/3	D 892	ml	5/10/5
Foam, 5 min settling, seq. 1/2/3	D 892	ml	0/0/0
Rust prevention test, proc. A and B, 24h	D 665		pass
Copper strip, 3h, 100°C	D 130		1
FZG Test, A/8.3/90	DIN 51354	load stage	10

Table 8-5 The above figures are not specifications. They are typical figures obtained within production tolerances.

8.8 Properties and Specifications of Lubricant

Berulub Lubricant Properties
Suitable for low temperatures
Prevents "stick-slip" (sticking during sliding)
Extended lubrication intervals
Very good adhesion
Does not drip or melt
Resistant to hot and cold water, water vapours, lactic acid, formic acid, acetic acid or fruit acid, as well as aqueous-alkaline and acidic disinfectants or cleaning agents
Contains PTFE

Table 8-6 Berulub Lubricant Properties

	Characteristics
Base oil	Ester
Thickener	Polytetrafluoroethylene (PTFE)
NLGI grade	3
Kinematic viscosity at 40 °C	5000.0 mm ² /s
Kinematic viscosity at 100 °C	340.0 mm ² /s
Operating temperature range	-15.5 °C to 150 °C
Colour / Appearance	White
Propellant	Dimethyl ether

Table 8-7 Characteristics

8.9 Specifications of Electrical Components

		44 ft
Battery	Type	EV240-12 (12V240Ah)
	Capacity	240Ah@10hr-snelheid tot 1,80V per cel @25 C
	Max. Discharge Current	2400A (5 sec)
	Normal Operating Temperature	25° C±5° C
	Recommended Maximum Charge Current	72 A
Connection Voltage		12 V
Rolling Current Connection		380 V (3 x 32 A)
Socket Voltage		220 V
Light Switches		220 V
Fuses per Group		16 A
Electrical Components Hydraulics		24 V
Battery Master Switch	Maximum Operating Voltage	48V, 32V DC & 12V DC single cycle: 48V DC
	Max. Continuous Current	5A-600 A
	Inrush Current (2 sec)	3,500 A
	Connection Bolt Size	3/8"-16 (accepts M10 connections)
	Moisture Ingress Protection	IP67/IP69K
	Ignition Protection	ISO 8846 & SAE J1171
Spirit Level Sensor	Moisture Ingress Protection	IP67, IP69K (with IP69K mating plug)
	Relative Humidity	0 - 95% (non-condensing, fully encapsulated housing)
	Power Supply Voltage	10 - 32 V dc
	Polarity Protection	Yes
	Power Consumption	50mA For CFM models (CANbus daisy-chained): max. internal T-junction current: 2.5A
	Operating Temperature	-40 .. +80 °C
Inductive Sensor	Operating Voltage	7....30V
	Output Type	NPN
	Output Polarity	DC
	Ambient Temperature	-40 .. +80 °C
	Mass	45 g
	Protection	IP68 / IP69K
Hydraulic Pump	Operating Voltage	16 - 32 V
	Overvoltage	36 V (1 hour) / 48 V (5 min.)
	Reverse Operating Voltage	-16 V (1 hour) / -32 V (10 hours)

Table 8-8 Specifications of Electrical Components



The specifications listed in the table above are a selection from the full specifications provided by the manufacturer. Expandable B.V. always recommends consulting the supplied

documentation from the manufacturer of the electrical components, as this documentation is authoritative.

8.10 Pictograms

The following pictograms are used in this manual:



















Description		Description		Description	
	Important notice!		Maximum number of persons/maximum load		Delivery information.
	Danger of entrapment!		Read this information before you start!		Parts information.
	Error		Risk of damage to the system!		Information regarding daily use!
	Wear safety shoes		Wear head protection		Conditions set by Expandable B.V..
	Wear work gloves		Wear safety clothing		Surface treatment
	Wear hearing protection		Wear safety glasses		Good
	Inflate bellows		Deflate bellows		

Table 8-9 Pictograms

any questions?
contact us

Expandable B.V.
Meerheide 25
5521 DZ Eersel
The Netherlands

+31(0)85 890 21 88
info@expandable.nl



EXPANDABLE
movable spaces

Part no.: 162033 EN (UK)-1
Edition: 03/2026

www.expandable-trailers.com